

Portable Industrial Tools For Professionals

Exceeding customer expectations since 1977



Drilling Beveling Grinding Sawing Lifting

 **EUROBOOR**

FOR PROFESSIONALS BY PROFESSIONALS

Catalog - USA

Our mission:

"Exceeding customer expectations by developing and providing safe, premium and innovative portable drilling and cutting solutions."



The Netherlands office

Kryptonstraat 110
2718 TD Zoetermeer
t +31(0)79 361 49 90
e info.nl@euroboor.com



Brasil office

Rua Harpia 438 Novo Horizonte,
Serra, 29.163-308
Espírito Santo, Brasil
t +55 27 98827 1043
e contato.br@euroboor.com

Russia offices

st. Latyshskih Strelkov 29/4
195213 St.Petersburg
t 8 800 201 41 78
8 812 679 00 28
e info.russia@euroboor.com

st. Geroev Tankograda 46 P
454084 Chelyabinsk
t 8 800 201 41 78 (add 222)
8 812 679 00 28 (add 222, 104)
e ural@euroboor.com

UAE office

SAIF Zone A2-084
P.O. Box No: 120085, Sharjah
t +971 655 784 54
e info.uae@euroboor.com

USA office

160 White Oak Road
Hayden, AL 35079
t +1 844 266 8527
e info.usa@euroboor.com

China office

2nd Floor, HongJI Building, No9#, LiuShi Road,
LIXiang Village, Tangshi
Yangshe Town, Zhangjiagang City,
Jiangsu China 215600
t +8651258549182
e info@euroboorchina.com

Go to our website
for more information:
www.euroboor.com

Design and lay-out
VormPro (NL)

This catalog is for those interested in our company. For more information contact us by email or phone.

No part of this catalog may be reproduced or copied without prior written consent.

All pictures in this catalog are meant to give an impression. This catalog has been compiled with the utmost care. Nevertheless it is possible that certain information included is now outdated or no longer complete. Euroboor is not responsible for results of actions taken purely on the basis of this catalog. Euroboor therefore recommends seeking our professional expert advice before undertaking any actions purely based on the information in this catalog.

 **EUROBOOR**

ISO9001 certified company



Table of contents

Our vision	4	Overview Mag Drills	6	Features explained	8
------------	---	---------------------	---	--------------------	---

Drilling

Small scale fabrication

ECO.30S+	12
ECO.32+	13

Big scale fabrication

ECO.40/2+	14
ECO.40S+	16
ECO.40S+/M	17
ECO.50+/T	18
ECO.50S+	19
ECO.55S+/T	22
ECO.55S+/TA	23
ECO.60S+	25

Heavy scale fabrication

ECO.80S+	27
ECO.100S+/T	28
ECO.100S+/TD	29
ECO.100S+/CT	30
ECO.200S/T	31

Specials

TUBE.30S+	34
TUBE.55S+/T	35
ECO.36+	36
ECO.36+/T	37
F16+	38
VAC.50S+	39
EBM.360	40
EBM.36/P-18V	41
AIR.55	42
TUBE.55/AIR	43

Accessories

Weldon setup overview	46
Twist drill setup overview	47
Armature Kit	48
Pipe adapter kit	50
WeINit kit	50
Extensions	51
Connections	51
Morse Taper reductions	51
Arbors	52
Drill chuck connections	53
Twist drill chucks	53

Cutting lubricants

Cutting oils	56
Sprays	57
Paste	57
Gearbox oil	57

Annular cutters

Overview	61
HSS	62
HSS sets	65
HSS Stack	66
HSS-Cobalt	68
TCT	70
TCT sets	76
TCT Hole Saw	77

Pilot pins	78
Pilot pin recommendations	80
ERM.100/3	82

Drilling tools

Weldon twist drills	83
Drills Bit sets	83
Countersinks	84
Step drills	84
After drilling aid	84

Tapping tools

Tapping chucks	85
Tap holders (Weldon)	85

Beveling

B60	86
B60S	87
B45S	88
BM45AIR	89

Sawing

EDC.355	92
EHC.230/3	93

Lifting

ELM.125	94
ELM.250	94
ELM.500	94
ELM.1000	94
ELM.2000	94

Information

Service	96
Stay connected	97
General terms and conditions	98
Euroboor worldwide	99

Grinding

ADG.2A	90
ADG.2S	90
ADG.2E	90

Our vision

Ever worked with industrial tools which did not deliver on the promised quality and output? Heavy machines which are inconvenient to use and therefore cost both you and your employees a lot of time and effort?

At Euroboor we believe, ever since our founding in 1977, that it can be done differently. That a professional like you must be able to rely on a professional supplier. Which has led us to become a major player in the industrial world, with our own factory and several offices worldwide. All because we have always listened to our customers and to the demands from the market.

Our customers are the ones who use our tools every day. Therefore they are our key indicators when it comes to the development and production. To which the starting point is clear: good is not good enough! Euroboor always goes one step further. With our

production methods and technical approach, it is our goal to develop lighter, stronger, safer and more reliable tools. In addition, we test our tools thoroughly from the start of the development process all the way up to production.

Our vision is focused on developing innovative portable tools that add value for our customers and facilitate them in their daily work. We never lose sight of safety, sustainability, time & cost savings. Our mission is always clear: exceeding customer's expectations by developing and providing premium and innovative portable drilling and cutting solutions.



Focus



Quality



Efficiency



Safety



From development, to extensive prototype testing to producing premium tools

The production of our magnetic drilling machines takes place in our own and highly organized facility where we are able to produce our tools to the highest standards. Having our own facility also means we are able to adapt, evolve and innovate easily and therefore make new developments and tailor-made products available to you quickly.

To be able to develop and provide premium and innovative portable drilling and cutting solutions which exceed our customer expectations we test each and every concept, sample and component to its limits, and beyond. Our own testing facility allows us to extensively test our self-produced prototypes and expose them to all necessary endurance tests.



Sustainability & Ecological awareness

By continuously updating our production process we are able to shorten production times and minimize usage of raw materials, thus consuming and wasting less material which means we reduce our use of natural resources. The use of virgin, but renewable, raw materials during our advanced manufacturing process helps us to develop lighter, stronger and more reliable and efficient tools. Making their practical use clear: faster and more premium results with reduced operating time. This translates directly into reduced energy use, causing less stress on the environment.

With our drilling and cutting solutions, we bring added value for our customers and facilitate them in their daily work. To do so we have developed a wide range of premium and innovative portable magnetic drilling machines. No matter the size, location or difficulty of your drilling job we have the best solution for you!

Machines	Annular cutting ¹	Twist drilling ¹	Countersinking ¹	Tapping ¹	Milling ¹	Length	Width	Height	Stroke
ECO.30_{S+}	Ø 1 3/16"	Ø 1/2" (Weldon)	Ø 1 3/8" (Weldon)	n/a	n/a	10 13/16"	7 1/2"	11 9/16" - 15 1/16"	3 9/16"
ECO.32₊	Ø 1 1/4"	Ø 1/2"	Ø 1 9/16"	n/a	n/a	12 5/8"	8 1/4"	14 9/16" - 20 3/16"	5 15/16"
ECO.40/2₊	Ø 1 9/16"	Ø 1/2"	Ø 1 3/4"	n/a	n/a	12 5/8"	8 1/4"	15 9/16" - 21 1/4"	5 15/16"
ECO.40_{S+}	Ø 1 9/16"	Ø 5/8"	Ø 1 3/4"	n/a	n/a	10 3/8"	7 1/16"	14 3/16" - 17 5/16"	5 11/16"
ECO.40_{S+M}	Ø 1 9/16"	Ø 5/8"	Ø 1 3/4"	n/a	n/a	10 3/8"	7 1/16"	14 7/16" - 17 5/8"	5 11/16"
ECO.50_{+T}	Ø 2"	Ø 15/16"	Ø 2 3/16"	Ø 13/16"	n/a	12 5/8"	8 1/4"	15 3/16" - 21 1/4"	6 11/16"
ECO.50_{S+}	Ø 2"	Ø 15/16"	Ø 2 3/16"	n/a	n/a	12 5/8"	7 7/8"	17 1/2" - 24 3/16"	6 11/16"
ECO.55_{S+T}	Ø 2 3/16"	Ø 15/16"	Ø 2 3/8"	Ø 13/16"	n/a	12 5/8"	7 7/8"	19 5/16" - 26"	6 11/16"
ECO.55_{S+TA}	Ø 2 3/16"	Ø 15/16"	Ø 2 3/8"	Ø 113/16"	n/a	13 9/16"	12"	19 5/16" - 26"	6 11/16"
ECO.60_{S+}	Ø 2 3/8"	Ø 15/16"	Ø 2 9/16"	n/a	n/a	12 5/8"	7 7/8"	17 13/16" - 24 1/2"	6 11/16"
ECO.80_{S+}	Ø 3 1/8"	Ø 1 1/4"	Ø 3 3/8"	n/a	n/a	14 3/8"	12 3/16"	20 1/16" - 27 15/16"	10 1/4"
ECO.100_{S+T (D)}	Ø 4"	Ø 1 1/4"	Ø 4 1/8"	Ø 1 3/16"	n/a	14 3/8"	12 3/16"	20 1/16" - 27 15/16" 20 1/4" - 28 1/8" (TD)	10 1/4"
ECO.100_{S+CT}	Ø 4"	Ø 1 1/4"	Ø 4 1/8"	Ø 1 3/16"	Ø 9/16"	19 9/16"	14 3/4"	24 3/16" - 31 1/4"	10 1/4"
ECO.200S/T	Ø 8"	Ø 2"	Ø 8 1/16"	Ø 1 7/8"	n/a	20 1/4"	10 7/16"	25 9/16" - 35 5/8"	10 1/16"

TUBE.30_{S+}	Ø 1 3/16"	Ø 1/2" (Weldon)	Ø 1 3/8"	n/a	n/a	10 13/16"	7 1/4"	12 13/16" - 16 3/8"	3 9/16"
TUBE.55_{S+T}	Ø 2 3/16"	Ø 15/16"	Ø 2 3/8"	Ø 13/16"	n/a	12 5/8"	8 1/4"	20 9/16" - 27 1/4"	6 11/16"
ECO.36_{- (T)}	Ø 1 7/16"	9/16" (Weldon)	1 9/16" (Weldon)	1 3/9" (T)	n/a	12 3/16"	5 5/16"	6 1/2"	1 9/16"
F16₊	n/a	Ø 5/8"	n/a*	n/a	n/a	12 3/16"	6 11/16"	12 13/16" - 19 1/2"	6 11/16"
VAC.50_{S+}	Ø 1 3/16" (steel and hard metals) Ø 2" (other metals and plastic)	Ø 2" (steel and hard metals) Ø 15/16" (other metals and plastic)	Ø 2 3/16"	n/a	n/a	16 15/16"	7 1/2"	16 17/32" - 23 7/32"	6 11/16"
EBM.360	Ø 1 7/16"	Ø 1/2"	Ø 1 9/16"	n/a	n/a	11 11/16"	4 7/16"	16 9/16" - 24"	9 1/16"
EBM.36/P-18V	Ø 1 7/16"	Ø 1/2"	Ø 1 9/16"	n/a	n/a	12 13/16"	9 1/4"	14 9/16" - 16 1/8"	5 1/2"
AIR.55 TUBE.55/AIR	Ø 7/16" - 2 1/16" (HSS) Ø 7/16" - 2 3/16" (TCT)	Ø 1/16" - 15/16"	Ø 2 3/16"	n/a	n/a	14 15/16" 13 9/16" (Tube)	9 5/8"	24 3/16" - 27 3/4" 24 13/16" - 28 3/4" (Tube)	6 9/16"

1) Maximum diameter, 2) Exclusive power cord and/or handle(s), * Hand drill dependable

Our large selection of magnetic drilling machines offers you the most suitable choice for any situation! Our + editions are equipped with innovative electronics that protect both machine and user. Want a reliable and safe machine for your professional jobs? Then we have the machine for you.

The + machines benefit from additional features, such as:

- Gyro-Tec safety
- Power surge protection
- Power fluctuation protection
- Automatic shut-off
- Carbon brush wear indicator

Weight*	Magnet (l x w x h)	Magnetic force	Motor power	Total power	Speed (no load)	Speed (load)	Spindle	Power source
18.7 lbs*	6 5/16" x 3 1/8" x 1 7/16"	2,645 lbs	8.2 A	8.6 A	I 775 rpm	I 400 rpm (8.2 A)	3/4"	110 - 120 V / 60 Hz
24.3 lbs*	6 5/16" x 3 1/8" x 1 5/8"	3,305 lbs	9.1 A	9.5 A	I 775 rpm	I 440 rpm (9.1 A)	3/4"	
25.4 lbs*	6 5/16" x 3 1/8" x 1 5/8"	3,305 lbs	8.2 A	8.6 A	I 720 rpm II 1,300 rpm	I 315 rpm (8.2 A) II 560 rpm (8.2 A)	3/4"	
23.1 lbs*	6 5/16" x 3 1/8" x 1 5/8"	3,305 lbs	10.5 A	10.9 A	I 600 rpm	I 380 rpm (10.5 A)	3/4"	
26.9 lbs*	6 5/8" x 3 5/16" x 1 15/16"	4,079 lbs	10.5 A	10.9 A	I 600 rpm	I 380 rpm (10.5 A)	3/4"	
29.8 lbs*	6 11/16" x 3 3/8" x 1 7/8"	4,080 lbs	11.4 A	12.5 A	I 100 - 280 rpm II 185 - 530 rpm	I 250 rpm (11.4 A) II 460 rpm (11.4 A)	MT2 3/4"	
26.5 lbs*	6 5/16" x 3 1/8" x 1 5/8"	3,750 lbs	11.4 A	11.8 A	I 380 rpm II 690 rpm	I 235 rpm (11.4 A) II 415 rpm (11.4 A)	MT3 3/4"	
28,4 lbs*	6 5/8" x 3 5/16" x 1 15/16"	4,080 lbs	14.5 A	15.4 A	I 60 - 275 rpm II 100 - 500 rpm	I 60 - 275 rpm (14.5 A) II 100 - 500 rpm (14.5 A)	MT3 3/4"	
34.8 lbs*	6 5/8" x 3 5/16" x 1 15/16"	4,080 lbs	14.5 A	15.4 A	I 60 - 275 rpm II 100 - 500 rpm	I 60 - 275 rpm (14.5 A) II 100 - 500 rpm (14.5 A)	MT3 3/4"	
28.4 lbs*	6 5/8" x 3 5/16" x 1 5/16"	4,080 lbs	14.5 A	15.4 A	I 60 - 275 rpm II 100 - 500 rpm	I 60 - 275 rpm (14.5 A) I 100 - 500 rpm (14.5 A)	MT3 3/4"	
60.2 lbs*	8 11/16" x 4 5/16" x 2 1/2"	6,615 lbs	15.4 A	16.4 A	I 200 rpm II 320 rpm III 415 rpm IV 650 rpm	I 150 rpm (15.4 A) II 200 rpm (15.4 A) III 275 rpm (15.4 A) IV 400 rpm (15.4 A)	MT3 1 1/4"	
61.3 lbs* 68,3 lbs (TD) *	8 11/16" x 4 5/16" x 2 1/2"	6,615 lbs	17.3 A	18.6 A	I 42 - 110 rpm II 65 - 190 rpm III 140 - 400 rpm IV 220 - 620 rpm	I 85 rpm (17.3 A) II 152 rpm (17.3 A) III 270 rpm (17.3 A) IV 480 rpm (17.3 A)	MT3 1 1/4"	
121 lbs*	8 11/16" x 8 11/16" x 2 1/2"	9,700 lbs	17.3 A	18.6 A	I 42 - 110 rpm II 65 - 190 rpm III 140 - 400 rpm IV 220 - 620 rpm	I 42 rpm (17.3 A) II 65 rpm (17.3 A) III 140 rpm (17.3 A) IV 220 rpm (17.3 A)	MT3 1 1/4"	
129 lbs*	13 3/4" x 4 15/16" x 2 9/16"	8,113 lbs	2,600 W (220 V)	17 A (110 V) 2,750 W (220 V)	I 40 - 80 rpm II 60 - 125 rpm III 145 - 300 rpm IV 230 - 470 rpm	I 29 - 75 rpm (23.6 A) II 46 - 120 rpm (23.6 A) III 110 - 285 rpm (23.6 A) IV 174 - 452 rpm (23.6 A)	MT4 1 1/4"	110 - 120 V / 220 - 240 V / 50 - 60 Hz
22.7 lbs*	7 3/8" x 6 1/2" x 3 1/4"	1,175 lbs	8.2 A	8.6 A	I 775 rpm	I 400 rpm (8.2 A)	3/4"	110 - 120 V / 60 Hz
35.3 lbs*	10 13/16" x 7 1/2" x 3 9/16"	1,984 lbs	14.6 A	15.4 A	I 60 - 275 rpm II 100 - 500 rpm	I 60 - 275 rpm (14.6 A) II 100 - 500 rpm (14.6 A)	MT3 3/4"	
22.7 lbs*	6 5/16" x 3 1/8" x 1 7/16"	2,645 lbs	9.5 A 8.5 A (T)	10 A 9 A (T)	I 700 rpm I 120 - 500 rpm (T)	I 400 rpm (9.5 A) I 120 - 400 rpm (8.5 A) (T)	3/4"	
16.5 lbs*	6 5/16" x 3 1/8" x 1 7/16"	2,645 lbs	n/a*	n/a*	n/a*	n/a*	n/a*	
21.8 lbs*	11 13/16" x 5 1/2" x 13/16"	661 lbs	11.4 A	11.8 A	I 380 rpm II 690 rpm	I 235 rpm (11.4 A) II 415 rpm (11.4 A)	MT3 3/4"	
25.8 lbs*	6 5/16" x 3 1/8" x 1 5/8"	3,750 lbs	35.1 A DC	36.5 A DC	I 506 rpm	I 375 rpm (35.1 A DC)	3/4"	37 V battery 2.6 Ah li-ion
22.4 lbs*	6 3/16" x 3 3/8" x 1 3/4"	1,433 lbs			I 530 rpm	I 430 rpm	3/4"	18 V battery 5 or 9 Ah li-ion
36.4 lbs* 36.8 lbs* (Tube)	7 3/16" x 3 15/16" x 2 3/16" 10 13/16" x 7 1/2" x 3 9/16" (Tube)	1,984 lbs	n/a	n/a	I 380 rpm	n/a	MT3 3/4"	Air, min. 6.3 bar, max. 8 bar, consumption 1.1 m³/min

Euroboor magnetic drilling machines



Our magnetic drilling machines are designed and engineered to the highest standards. With our many years of experience we dare to say that we know what you need. We stay in charge of today's and tomorrow's demands by being active in the field and remaining in close contact with the people that actually use our machines.

We develop, design, engineer and produce our magnetic drilling machines in-house.

We only use the best and most trustworthy suppliers or we roll up our sleeves and produce the required parts ourselves. The same applies for all our drills and cutters.

Every stage in the production process is subjected to stringent durability tests, and pre-shipment inspections are equally meticulous.

Only thus can we ensure you our core values: Efficiency, Focus, Quality, and Safety.

We pride ourselves on our line-up of magnetic drilling machines ranging from small scale fabrication to special purposes and designed to offer you the best possible options. Regardless of your company size, specialism or tasks at hand, you will find the perfect match at Euroboor.





Safety features explained

Magnet LED-indicator

The control panel on your magnetic drilling machine is designed for maximum ease of use and safety. Here you can find the magnet LED-indicator. There are two options:



The LED-indicator lights up **GREEN** when the generated magnetic force is sufficient. You can now safely start your drilling job.

The LED-indicator lights up **RED** when the generated magnetic force is insufficient due to:

- Surface not being flat
- Workpiece not being magnetisable (e.g. aluminium)
- Workpiece is coated or painted
- Workpiece is not thick enough

If resolving the above doesn't help, the magnet doesn't function properly. Don't start your drilling job, but have your machine checked and serviced.

Gyro-Tec safety

Gyro-Tec safety features a gyroscopic sensor which detects acceleration and displacement in any direction. The **Gyro-Tec** safety feature engages three seconds after the motor is started. Whenever the machine recognizes a sudden or unwanted movement the motor will be shut down automatically by the machine's electronics. This safety functionality offers extra protection in various circumstances, such as:

- Sudden loss of magnetic force while in operation
- Excessive vibration caused by incorrect drilling procedure, worn-out cutting tools, etc.
- Sudden displacement of the workpiece to which the magnetic drilling machine is attached

By the motor shutting down automatically, risk of damaging or hurting the machine, tools, workpiece and operator is reduced.

Integrated motor cable

The frame of your magnetic drilling machine is designed for maximum safety and comfort. It is provided with an ergonomic handle and part of the machines in our portfolio have an integrated motor cable. The machines with integrated cable offer increased safety as the cable is completely incorporated in the frame. This prevents the user from getting caught in the cable and the cable from tearing or snapping off. It also prevents a lot of unnecessary repairs and therefore additional costs because the user can no longer lift and carry the machine by the motor cable, which often happens in practice.



2-way magnet

The 2-way magnet saves energy when the machine is not being used. The machine sticks sufficiently at half the magnetic force, this ensures you use less energy. The magnet generates less heat which makes the lifespan of the machine is longer. Only with full magnetic force the machine can be used for drilling.

Power protection

The power protection feature is two-fold; it consists of both power fluctuation protection and power surge protection. Special safety components built into the electronics of the machine make it more reliable in situations where power supply can be of varying quality due to factors:

- Around the workplace, for example caused by switching on high power or unreliable electrical devices, a broken circuit breaker or faulty wiring
- Outside the workplace, for example caused by an instable power grid or lightning

A machine with this feature is able to cope with standard rated voltage and frequency fluctuations ranging from:

- 110 Volt to 130 Volt and 45 Hz to 65 Hz, or
- 220 Volt to 240 Volt and 45 Hz to 65 Hz reducing the probability of breakdown and minimizing down-time and repair cost.

Power fluctuation protection



When the frequency is too high (above 65 Hz) or too low (below 45 Hz), the motor will not start. If the frequency of the power supply falls outside the range during your drilling job, the motor will shut off automatically. The machine will work again normally when the normal frequency has been restored.*

Power surge protection



Beyond the rated voltage, a machine with this feature is able to cope with voltage spikes up to 4,000 Volt (1-2 μ s)*, which could be caused by nearby welding activities. Depending on the height of the spike, it may be necessary to replace built-in fuses, the control unit or the power switch, but other valuable parts like the motor and magnet will be protected.

Overload protection



To ensure safe use and longer lifetime of the motor the machine profits by overload protection. While you are using the machine there are different types of load levels, which correlate with the feed pressure. Once you go from close to overload to exceeding the overload limit the machine will automatically stop the motor.

Smart Restart



When the motor is in overload, the **Smart Restart** torque control technology ensures trouble-free continuation of your drilling job. When the feed pressure is reduced, the machine's electronics recognise the reduction and the motor continues within a few seconds.

Overheat protection



To prevent damage, machines with this feature are equipped with a sensor which will shut off the motor automatically when the temperature of the field coil exceeds 100° C - 105° C.

*Disclaimer: Euroboor is not liable for any damage caused to the machine due to electrical problems in the workplace. Above mentioned protection is not guaranteed in all cases of voltage spikes and/or frequency fluctuations. Euroboor accepts no liability when it comes to the power protection not functioning or functioning poorly.



Carbon brushes

The carbon brushes on the magnetic drilling machine are equipped with two protective features. The purpose of both features is to schedule timely service and avoid additional costs by unexpected downtime or unnecessary part replacement.

Carbon brush wear indicator



On the motor housing you will find an integrated LED light. Under normal circumstances this light is off. The LED light will start burning **RED** when the carbon brushes are worn to a level where it is advised to replace them.

Automatic shut-off



When the carbon brushes are actually worn to a level where replacement is needed, the motor will be shut-off automatically. This prevents the armature from being damaged. Once shut off, the LED-indicator is no longer lit.

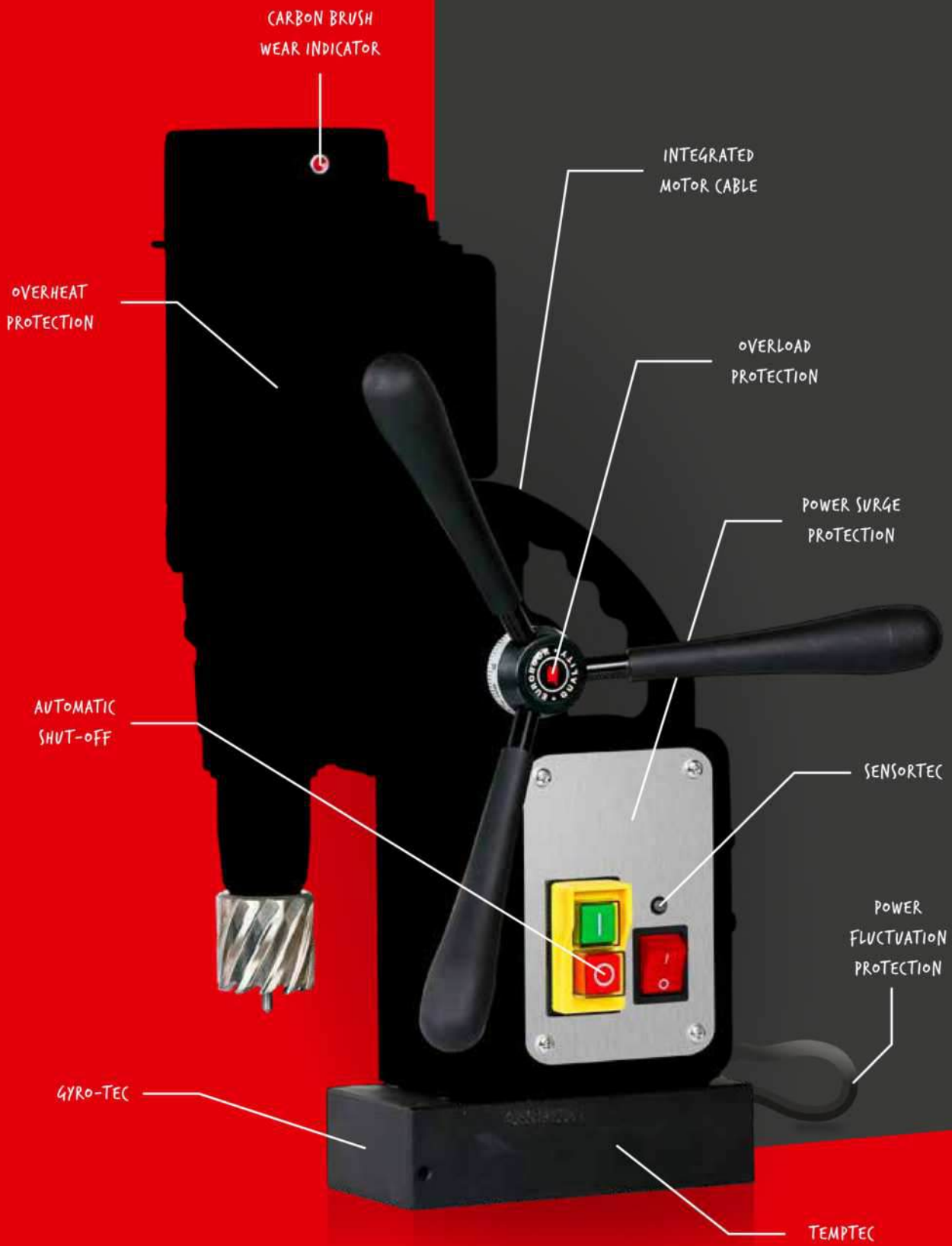



ECO.30s+



Watch our machines in action on:
www.youtube.com/euroboorby

Technical data	
Annular cutting	Ø 1/2" - 1 3/16"
Twist drilling (Weldon)	Ø 1/16" - 1/2"
Countersinking (Weldon)	Ø 3/8" - 1 3/8"
Length	10 13/16"
Width	7 1/2"
Height	11 9/16" - 15 1/16"
Stroke	3 9/16"
Weight*	18.7 lbs
Magnet (l x w x h)	6 5/16" x 3 1/8" x 1 7/16"
Magnetic force	2,645 lbs
Motor power	8.2 A
Total power	8.6 A
Speed (no load)	I 775 rpm
Speed (load 8.2 A)	I 400 rpm
Spindle (Weldon)	3/4"
Voltage	110 - 120 V / 60 Hz

*Exclusive power cord and handles

Benefits

- Lightest Ø 1 3/16" magnetic drilling machine:
 - Most compact in class
 - Incredibly easy to handle
- Direct spindle drive and integrated tool cooling and lubrication
- Integrated slide for:
 - High accuracy
 - Enlarged lifecycle
 - Minimal vibration
- High-precision height adjustment for:
 - Low maintenance
 - Minimal wear correction
- Strong dual coil CNC machined 2-way magnet, causing the machine to use less energy, generate less heat and therefore lasts longer
- Reversible handles: to enable you to change the operation side of the feed handles in confined spaces
- Reduced risk of damaging machine, tools and workpiece and hurting operator
- Suitable for use in areas and workplaces where power supply is of less quality
- Reduced risk of armature damage
- Reduced risk of control unit(s) damage
- Timely service notification to avoid additional cost by unexpected downtime or unnecessary part replacement
- Also available with permanent TUBE magnet for both pipe and flat material (page. 44)

Features

Power surge protection	Power fluctuation protection	Gyro-Tec	Automatic shut-off
Oil lubricated gearbox	Carbon brush wear indicator	2-way magnet (TempTec)	18.7 weight

CARBON BRUSH WEAR INDICATOR



Optimised motor efficiency and lifetime of key components due to oil lubricated gearbox





ECO.32+



Watch our machines in action on:
www.youtube.com/euroboorby

Technical data

Annular cutting	Ø 1/2" - 1 1/4"
Twist drilling	Ø 1/16" - 1/2"
Countersinking	Ø 3/8" - 1 9/16"
Length	12 5/8"
Width	8 1/4"
Height	14 9/16" - 20 3/16"
Stroke	5 15/16"
Weight*	24.3 lbs
Magnet (l x w x h)	6 5/16" x 3 1/8" x 1 5/8"
Magnetic force	3,305 lbs
Motor power	9.1 A
Total power	9.5 A
Speed (no load)	I 775 rpm
Speed (load 9.1 A)	I 440 rpm
Spindle (Weldon)	3/4"
Voltage	110 - 120 V / 60 Hz

*Exclusive power cord and handles

Benefits

- One-speed gearbox
- Detachable spindle drive and integrated tool cooling and lubrication
- Integrated slide for:
 - High accuracy
 - Enlarged lifecycle
 - Minimal vibration
- High-precision height adjustment for:
 - Low maintenance
 - Minimal wear correction
- Strong dual coil CNC machined 2-way magnet, causing the machine to use less energy, generate less heat and therefore lasts longer
- Reduced risk of damaging machine, tools and workpiece and hurting operator
- Suitable for use in areas and workplaces where power supply is of less quality
- Reduced risk of armature damage
- Reduced risk of control unit(s) damage
- Timely service notification to avoid additional cost by unexpected downtime or unnecessary part replacement

CARBON BRUSH WEAR INDICATOR



Features

- Power surge protection
- Power fluctuation protection
- Gyro-Tec
- Automatic shut-off
- Carbon brush wear indicator
- 2-way magnet (TempTec)
- Magnet LED-indicator (SensorTec)



ECO.40/2+



Watch our machines in action on:
www.youtube.com/euroboorby

Technical data	
Annular cutting	Ø 1/2" - 1 9/16"
Twist drilling	Ø 1/16" - 1/2"
Countersinking	Ø 3/8" - 1 3/4"
Length	12 5/8"
Width	8 1/4"
Height	15 9/16" - 21 1/4"
Stroke	5 15/16"
Weight*	25.4 lbs
Magnet (l x w x h)	6 5/16" x 3 1/8" x 1 5/8"
Magnetic force	3,305 lbs
Motor power	8.2 A
Total power	8.6 A
Speed (no load)	I 720 rpm
	II 1,300 rpm
Speed (load 8.2 A)	I 315 rpm
	II 560 rpm
Spindle (Weldon)	3/4"
Voltage	110 - 120 V / 60 Hz

*Exclusive power cord and handles

Benefits

- Particularly suitable for both annular cutting and twist drilling
- Detachable spindle drive and integrated tool cooling and lubrication
- Two-speed gearbox
- Integrated slide for:
 - High accuracy
 - Enlarged lifecycle
 - Minimal vibration
- High-precision height adjustment for:
 - Low maintenance
 - Minimal wear correction
- Strong dual coil CNC machined 2-way magnet causing the machine to use less energy, generate less heat and therefore lasts longer
- Reduced risk of damaging machine, tools and workpiece and hurting operator
- Suitable for use in areas and workplaces where power supply is of less quality
- Reduced risk of armature damage
- Reduced risk of control unit(s) damage
- Timely service notification to avoid additional cost by unexpected downtime or unnecessary part replacement



Features

- Power surge protection
- Power fluctuation protection
- Gyro-Tec
- Automatic shut-off
- Carbon brush wear indicator
- Magnet LED-indicator (SensorTec)
- 2-way magnet (TempTec)

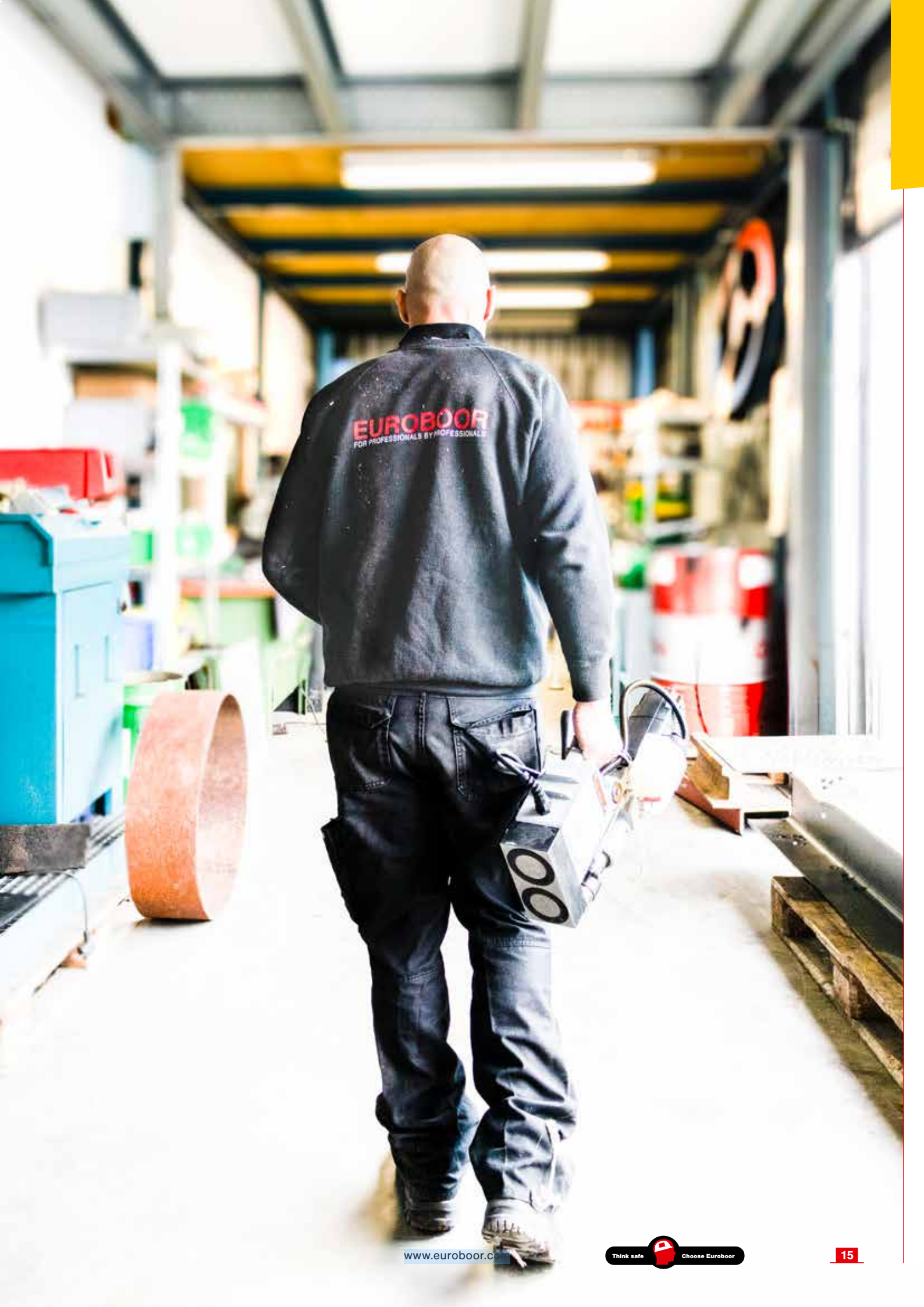



ECO.40s+



Watch our machines in action on:
www.youtube.com/euroboorby

Technical data	
Annular cutting	Ø 1/2" - 1 9/16"
Twist drilling	Ø 1/16" - 5/8"
Countersinking	Ø 3/8" - 1 3/4"
Length	10 3/8"
Width	7 1/16"
Height	14 3/16" - 17 5/16"
Stroke	5 11/16"
Weight*	23.1 lbs
Magnet (l x w x h)	6 5/16" x 3 1/8" x 1 5/8"
Magnetic force	3,305 lbs
Motor power	10.5 A
Total power	10.9 A
Speed (no load)	I 600 rpm
Speed (load 10.5 A)	I 380 rpm
Spindle (Weldon)	3/4"
Voltage	110 - 120 V / 60 Hz

*Exclusive power cord and handles



Benefits

- Lightest Ø 1 9/16" magnetic drilling machine
- Fits cutters up to 4 5/16" DoC
- High-efficiency motor with less heat generation
- High-accuracy capstan hub
- Direct spindle drive and integrated tool cooling and lubrication
- Integrated slide for:
 - High accuracy
 - Enlarged lifecycle
 - Minimal vibration
- High-precision height adjustment for:
 - Low maintenance
 - Minimal wear correction
- Strong dual coil CNC machined 2-way magnet, causing the machine to use less energy, generate less heat and therefore lasts longer
- Reduced risk of damaging machine, tools and workpiece and hurting operator
- Suitable for use in areas and workplaces where power supply is of less quality
- Reduced risk of armature damage
- Reduced risk of control unit(s) damage
- Timely service notification to avoid additional cost by unexpected downtime or unnecessary part replacement
- Reversible handles: to enable you to change the operation side of the feed handles in confined spaces

Features

Power surge protection	Power fluctuation protection	Gyro-Tec	Integrated motor cable
Automatic shut-off	Oil lubricated gearbox	Carbon brush wear indicator	2-way magnet (TempTec)
Magnet LED-indicator (SensorTec)			

Optimised motor efficiency and lifetime of key components due to oil lubricated gearbox





ECO.40S+/M



Watch our machines in action on:
www.youtube.com/euroboorby

Technical data

Annular cutting	Ø 7/16" - 1 9/16"
Twist drilling	Ø 1/16" - 5/8"
Countersinking	Ø 3/8" - 1 3/4"
Length	10 3/8"
Width	7 1/16"
Height	14 7/16" - 17 5/8"
Stroke	5 11/16"
Weight*	26.9 lbs
Magnet (l x w x h)	6 5/8" x 3 5/16" x 1 15/16"
Magnetic force	4,079 lbs
Motor power	10.5 A
Total power	10.9 A
Speed (no load)	I 600 rpm
Speed (load 10.5 A)	I 380 rpm
Spindle (Weldon)	3/4"
Voltage	110 - 120 V / 60 Hz

*Exclusive power cord and handles



Benefits

- Fits cutters up to 4 5/16" DoC
- High-efficiency motor with less heat generation
- High-accuracy capstan hub
- Direct spindle drive and integrated tool cooling and lubrication
- Integrated slide for:
 - High accuracy
 - Enlarged lifecycle
 - Minimal vibration
- High-precision height adjustment for:
 - Low maintenance
 - Minimal wear correction
- Bigger and stronger dual coil CNC machined 2-way magnet, causing the machine to use less energy, generate less heat and therefore lasts longer
- Reduced risk of damaging machine, tools and workpiece and hurting operator
- Suitable for use in areas and workplaces where power supply is of less quality
- Reduced risk of armature damage
- Reduced risk of control unit(s) damage
- Timely service notification to avoid additional cost by unexpected downtime or unnecessary part replacement
- Reversible handles: to enable you to change the operation side of the feed handles in confined spaces

Larger magnet for power through paint, epoxy or rust.
"Bridge Drill"

Features

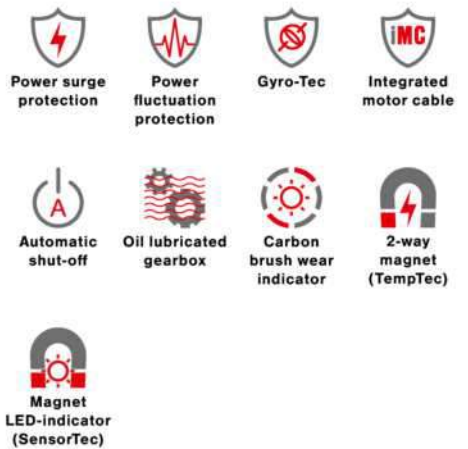

Optimised motor efficiency and lifetime of key components due to oil lubricated gearbox





ECO.50+ / T



Watch our machines in action on:
www.youtube.com/euroboorby

Technical data	
Annular cutting	Ø 1/2" - 2"
Twist drilling	Ø 1/16" - 15/16"
Countersinking	Ø 3/8" - 2 3/16"
Tapping	Ø 1/8" - 13/16"
Length	12 5/8"
Width	8 1/4"
Height	15 3/16" - 21 1/4"
Stroke	6 11/16"
Weight*	29.8 lbs
Magnet (l x w x h)	6 11/16" x 3 3/8" x 1 7/8"
Magnetic force	4,080 lbs
Motor power	11.4 A
Total power	12.5 A
Speed (no load)	I 100 - 280 rpm
	II 185 - 530 rpm
Speed (load 11.4 A)	I 250 rpm
	II 460 rpm
Spindle (Weldon)	MT2 3/4"
Voltage	110 - 120 V / 60 Hz

*Exclusive power cord and handles

Benefits

- Morse Taper 2 spindle with integrated tool cooling and lubrication
- Two-speed gearbox
- Integrated slide for:
 - High accuracy
 - Enlarged lifecycle
 - Minimal vibration
- High-precision height adjustment for:
 - Low maintenance
 - Minimal wear correction
- Strong dual coil CNC machined 2-way magnet causing the machine to use less energy, generate less heat and therefore lasts longer
- Reduced risk of damaging machine, tools and workpiece and hurting operator
- Suitable for use in areas and workplaces where power supply is of less quality
- Reduced risk of armature damage
- Reduced risk of control unit(s) damage
- Timely service notification to avoid additional cost by unexpected downtime or unnecessary part replacement



Features

Adjustable speed	Reverse rotation	Overheat protection	Power surge protection
Power fluctuation protection	Gyro-Tec	Automatic shut-off	Carbon brush wear indicator
Magnet LED-indicator (SensorTec)	2-way magnet (TempTec)	Tapping	



ECO.50s+



Watch our machines in action on:
www.youtube.com/euroboorby

Technical data

Annular cutting	Ø 1/2" - 2"
Twist drilling	Ø 1/16" - 15/16"
Countersinking	Ø 3/8" - 2 3/16"
Length	12 5/8"
Width	7 7/8"
Height	17 1/2" - 24 3/16"
Stroke	6 11/16"
Weight*	26.5 lbs
Magnet (l x w x h)	6 5/16" x 3 1/8" x 1 5/8"
Magnetic force	3,750 lbs
Motor power	11.4 A
Total power	11.8 A
Speed (no load)	I 380 rpm
	II 690 rpm
Speed (load 11.4 A)	I 235 rpm
	II 415 rpm
Spindle (Weldon)	MT3 3/4"
Voltage	110 - 120 V / 60 Hz

*Exclusive power cord and handles



Benefits

- High-accuracy capstan hub
- Morse Taper 3 spindle with integrated tool cooling and lubrication
- Integrated slide for:
 - High accuracy
 - Enlarged lifecycle
 - Minimal vibration
- High-precision height adjustment for:
 - Low maintenance
 - Minimal wear correction
- Strong dual coil CNC machined 2-way magnet, causing the machine to use less energy, generate less heat and therefore lasts longer
- Reduced risk of damaging machine, tools and workpiece and hurting operator
- Suitable for use in areas and workplaces where power supply is of less quality
- Reduced risk of armature damage
- Reduced risk of control unit(s) damage
- Timely service notification to avoid additional cost by unexpected downtime or unnecessary part replacement

Features



Optimised motor efficiency and lifetime of key components due to oil lubricated gearbox





Drilling as efficiently as you possibly can!

Euroboor's magnetic drilling machines that truly match your level of professionalism. There is no doubt your needs for fully assisted and fastest drilling with the highest accuracy are being met by our **ECO.55s+/T**, **ECO.55s+/TA** and **TUBE.55s+/T**



Top features

LED load indicators and digital display with Smart Restart technology

Easily accessible carbon brushes

When replacement is needed the motor will be shut-off automatically

Oil lubricated gearbox

Maximum lubrication

Integrated slide and gearbox system

- High accuracy
- Sturdy design enlarges lifecycle
- Minimal vibration

Automatic drill functionality with automatic return on the ECO.55s+/TA
(Only for annular cutting)

Z-profile guide rails

Maximum contact surface

Clear and easy controls

With RPM dial and right/left rotation functionality



LED load indicators

- | | |
|---|---|
| | |
| 1. Machine is on.
No load. | 2. Start drilling.
Ideal working load. |
| | |
| 3. When drilling.
Acceptable overload. | 4. Close to overload.
Reduce pressure. |

* Smart Restart

When the motor is in overload, the Smart Restart torque control technology () ensures trouble-free continuation of your drilling job. When the feed pressure is reduced, the machine's electronics recognises the reduction and the motor continues. This benefits your drilling process, saves time and prevents excessive tool wear and failure.

 A flashing red light with beeping sound means the overload limit is exceeded. The motor halts.*



ECO.55S+/T



Watch our machines in action on:
www.youtube.com/euroboorby

Technical data	
Annular cutting	Ø 1/2" - 2 3/16"
Twist drilling	Ø 1/16" - 15/16"
Countersinking	Ø 3/8" - 2 3/8"
Tapping	Ø 1/8" - 13/16"
Length	12 5/8"
Width	7 7/8"
Height	19 5/16" - 26"
Stroke	6 11/16"
Weight*	28,4 lbs
Magnet (l x w x h)	6 5/8" x 3 5/16" x 1 15/16"
Magnetic force	4.080 lbs
Motor power	14.5 A
Total power	15.4 A
Speed (no load)	I 60 - 275 rpm
	II 100 - 500 rpm
Speed (load 14.5 A)	I 60 - 275 rpm
	II 100 - 500 rpm
Spindle (Weldon)	MT3 3/4"
Voltage	110 - 120 V / 60 Hz

*Exclusive power cord and handles



Benefits

- Easily accessible carbon brushes. Motor will automatically shut-off in case of replacement
- High-accuracy capstan hub
- Morse Taper 3 spindle with integrated tool cooling and lubrication
- Integrated slide for:
 - High accuracy
 - Enlarged lifecycle
 - Minimal vibration
- High-precision height adjustment for:
 - Low maintenance
 - Minimal wear correction
- Strong dual coil CNC machined 2-way magnet causing the machine to use less energy, generate less heat and therefore lasts longer
- Reduced risk of damaging machine, tools and workpiece and hurting operator
- Suitable for use in areas and workplaces where power supply is of less quality
- Reduced risk of armature damage
- Reduced risk of control unit(s) damage
- Timely service notification to avoid additional cost by unexpected downtime or unnecessary part replacement
- Also available with permanent TUBE magnet for both pipe and flat material (page. 45)

Features

Adjustable speed	Reverse rotation	Overload protection	Overheat protection
Power surge protection	Power fluctuation protection	Gyro-Tec	Automatic shut-off
Smart Restart	Oil lubricated gearbox	Digital display	Carbon brush wear indicator
LED load indicators	2-way magnet (TempTec)	Magnet LED-indicator (SensorTec)	Tapping

Optimised motor efficiency and lifetime of key components due to oil lubricated gearbox





ECO.55S+/TA

Watch our machines in action on:
www.youtube.com/euroboorby

Technical data	
Annular cutting	Ø 1/2" - 2 3/16"
Twist drilling	Ø 1/16" - 15/16"
Countersinking	Ø 3/8" - 2 3/8"
Tapping	Ø 1/8" - 13/16"
Length	13 9/16"
Width	12"
Height	19 5/16" - 26"
Stroke	6 11/16"
Weight*	34.8 lbs
Magnet (l x w x h)	6 5/8" x 3 5/16" x 1 15/16"
Magnetic force	4,080 lbs
Motor power	14.5 A
Total power	15.4 A
Speed (no load)	I 60 - 275 rpm
	II 100 - 500 rpm
Speed (load 14.5 A)	I 60 - 275 rpm
	II 100 - 500 rpm
Spindle (Weldon)	MT3 3/4"
Voltage	110 - 120 V / 60 Hz

*Exclusive power cord and handles



Benefits

- Easily accessible carbon brushes. Motor will automatically shut-off in case of replacement
- High-accuracy capstan hub
- Morse Taper 3 spindle with integrated tool cooling and lubrication
- Integrated slide for:
 - High accuracy
 - Enlarged lifecycle
 - Minimal vibration
- High-precision height adjustment for:
 - Low maintenance
 - Minimal wear correction
- Strong dual coil CNC machined 2-way magnet causing the machine to use less energy, generate less heat and therefore lasts longer
- Reduced risk of damaging machine, tools and workpiece and hurting operator
- Suitable for use in areas and workplaces where power supply is of less quality
- Reduced risk of armature damage
- Reduced risk of control unit(s) damage
- Timely service notification to avoid additional cost by unexpected downtime or unnecessary part replacement

Features

Adjustable speed	Reverse rotation	Overload protection	Overheat protection
Power surge protection	Power fluctuation protection	Gyro-Tec	Automatic shut-off
Smart Restart	Oil lubricated gearbox	Digital display	Carbon brush wear indicator
LED load indicators	2-way magnet (TempTec)	Magnet LED-indicator (SensorTec)	Auto feed and return for cutters
Tapping			

Optimised motor efficiency and lifetime of key components due to oil lubricated gearbox







ECO.60s+



Watch our machines in action on:
www.youtube.com/euroboorby

Technical data

Annular cutting	Ø 1/2" - 2 3/8"
Twist drilling	Ø 1/16" - 15/16"
Countersinking	Ø 3/8" - 2 9/16"
Length	12 5/8"
Width	7 7/8"
Height	17 13/16" - 24 1/2"
Stroke	6 11/16"
Weight*	28.4 lbs
Magnet (l x w x h)	6 5/8" x 3 5/16" x 1 5/16"
Magnetic force	4,080 lbs
Motor power	14.5 A
Total power	15.4 A
Speed (no load)	I 60 - 275 rpm
	II 100 - 500 rpm
Speed (load 14.5 A)	I 60 - 275 rpm
	II 100 - 500 rpm
Spindle (Weldon)	MT3 3/4"
Voltage	110 - 120 V / 60 Hz

*Exclusive power cord and handles

Benefits

- High-accuracy capstan hub
- Morse Taper 3 spindle with integrated tool cooling and lubrication
- Integrated slide for:
 - High accuracy
 - Enlarged lifecycle
 - Minimal vibration
- High-precision height adjustment for:
 - Low maintenance
 - Minimal wear correction
- Strong dual coil CNC machined 2-way magnet causing the machine to use less energy, generate less heat and therefore lasts longer
- Reduced risk of damaging machine, tools and workpiece and hurting operator
- Suitable for use in areas and workplaces where power supply is of less quality
- Reduced risk of armature damage
- Reduced risk of control unit(s) damage
- Timely service notification to avoid additional cost by unexpected downtime or unnecessary part replacement



Features

Adjustable speed	Overload protection	Overload protection	Overheat protection
Power surge protection	Power fluctuation protection	Gyro-Tec	Automatic shut-off
Oil lubricated gearbox	Carbon brush wear indicator	2-way magnet (TempTec)	Magnet LED-indicator (SensorTec)

Optimised motor efficiency and lifetime of key components due to oil lubricated gearbox



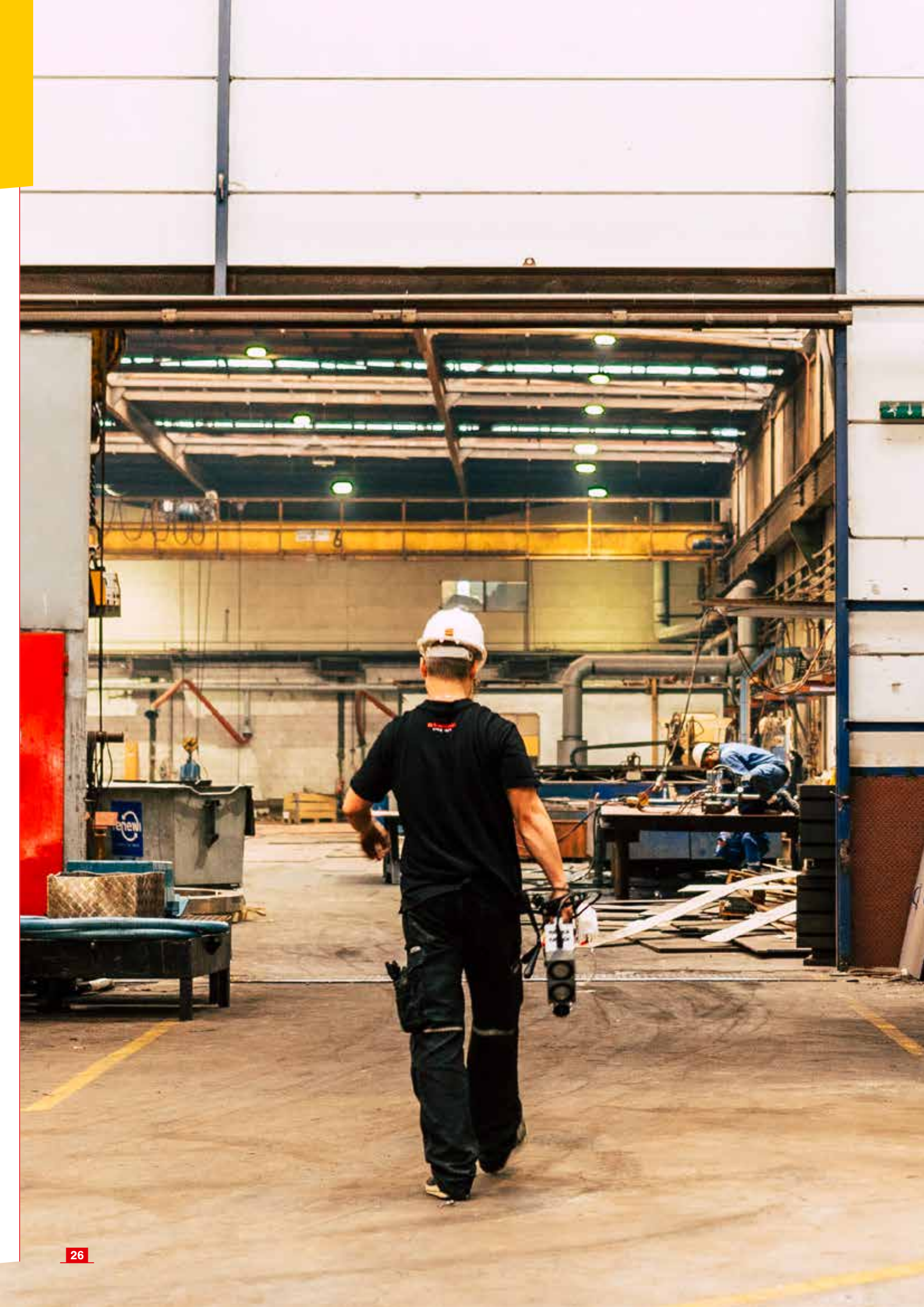



ECO.80S+

Watch our machines in action on:
www.youtube.com/euroboorby

Technical data	
Annular cutting	Ø 1/2" - 3 1/8"
Twist drilling	Ø 1/16" - 1 1/4"
Countersinking	Ø 3/8" - 3 3/8"
Length	14 3/8"
Width	12 3/16"
Height	20 1/16" - 27 15/16"
Stroke	10 1/4"
Weight*	60.2 lbs
Magnet (l x w x h)	8 11/16" x 4 5/16" x 2 1/2"
Magnetic force	6,615 lbs
Motor power	15.4 A
Total power	16.4 A
Speed (no load)	I 200 rpm
	II 300 rpm
	III 415 rpm
	IV 650 rpm
Speed (load 15.4 A)	I 150 rpm
	II 200 rpm
	III 275 rpm
	IV 400 rpm
Spindle (Weldon)	MT3 1 1/4"
Voltage	110 - 120 V / 60 Hz

*Exclusive power cord and handles



Benefits

- Morse Taper 3 spindle with integrated tool cooling and lubrication
- Strong dual coil CNC machined 2-way magnet, causing the machine to use less energy, generate less heat and therefore lasts longer
- Reduced risk of damaging machine, tools and workpiece and hurting operator
- Suitable for use in areas and workplaces where power supply is of less quality
- Reduced risk of armature damage
- Reduced risk of control unit(s) damage
- Timely service notification to avoid additional cost by unexpected downtime or unnecessary part replacement

Features

Overheat protection	Power surge protection	Power fluctuation protection	Gyro-Tec
Automatic shut-off	Oil lubricated gearbox	Carbon brush wear indicator	2-way magnet (TempTec)
Magnet LED-indicator (SensorTec)			

Optimised motor efficiency and lifetime of key components due to oil lubricated gearbox





ECO.100S+/T

Watch our machines in action on:
www.youtube.com/euroboorby

Technical data	
Annular cutting	Ø 1/2" - 4"
Twist drilling	Ø 1/16" - 1 1/4"
Countersinking	Ø 3/8" - 4 1/8"
Tapping	Ø 1/8" - 1 3/16"
Length	14 3/8"
Width	12 3/16"
Height	20 1/16" - 27 15/16"
Stroke	10 1/4"
Weight*	61.3 lbs
Magnet (l x w x h)	8 11/16" x 4 5/16" x 2 1/2"
Magnetic force	6,615 lbs
Motor power	17.3 A
Total power	18.6 A
Speed (no load)	I 42 - 110 rpm
	II 65 - 190 rpm
	III 140 - 400 rpm
	IV 220 - 620 rpm
Speed (load 17.3 A)	I 85 rpm
	II 152 rpm
	III 270 rpm
	IV 480 rpm
Spindle (Weldon)	MT3 1 1/4"
Voltage	110 - 120 V / 60 Hz

*Exclusive power cord and handles

Benefits

- Morse Taper 3 spindle with integrated tool cooling and lubrication
- Strong dual coil CNC machined 2-way magnet, causing the machine to use less energy, generate less heat and therefore lasts longer
- Reduced risk of damaging machine, tools and workpiece and hurting operator
- Suitable for use in areas and workplaces where power supply is of less quality
- Reduced risk of armature damage
- Reduced risk of control unit(s) damage
- Timely service notification to avoid additional cost by unexpected downtime or unnecessary part replacement

Features

Adjustable speed

Torque control

Reverse rotation

Overheat protection

Power surge protection

Power fluctuation protection

Gyro-Tec

Automatic shut-off

Oil lubricated gearbox

Carbon brush wear indicator

2-way magnet (TempTec)

Magnet LED-indicator (SensorTec)

Tapping

Optimised motor efficiency and lifetime of key components due to oil lubricated gearbox





ECO.100S+/TD



Watch our machines in action on:
www.youtube.com/euroboorby

Technical data

Annular cutting	Ø 1/2" - 4"
Twist drilling	Ø 1/16" - 1 1/4"
Countersinking	Ø 3/8" - 4 1/8"
Tapping	Ø 1/8" - 1 3/16"
Length	14 3/8"
Width	12 3/16"
Height	20 1/4" - 28 1/8"
Stroke	10 1/4"
Weight*	68,3 lbs
Magnet (l x w x h)	8 11/16" x 4 5/16" x 2 1/2"
Magnetic force	6.615 lbs
Motor power	17,3 A
Total power	18,6 A
Speed (no load)	I 42 - 110 rpm
	II 65 - 190 rpm
	III 140 - 400 rpm
	IV 220 - 620 rpm
Speed (load 17.3 A)	I 85 rpm
	II 152 rpm
	III 270 rpm
	IV 480 rpm
Spindle (Weldon)	MT3 1 1/4"
Voltage	110 - 120 V / 60 Hz

*Exclusive power cord and handles

Benefits

- Precise positioning swivel base, rotate the machine 30° both ways and slide 15-20 mm forward and backwards
- Morse Taper 3 spindle with integrated tool cooling and lubrication
- Strong dual coil CNC machined 2-way magnet, causing the machine to use less energy, generate less heat and therefore lasts longer
- Reduced risk of damaging machine, tools and workpiece and hurting operator
- Suitable for use in areas and workplaces where power supply is of less quality
- Reduced risk of armature damage
- Reduced risk of control unit(s) damage
- Timely service notification to avoid additional cost by unexpected downtime or unnecessary part replacement

Features



Adjustable speed



Torque control



Reverse rotation



Overheat protection



Power surge protection



Power fluctuation protection



Gyro-Tec



Automatic shut-off



Oil lubricated gearbox



Carbon brush wear indicator



2-way magnet (TempTec)



Magnet LED-indicator (SensorTec)



Swivelbase magnet



Tapping

Optimised motor efficiency and lifetime of key components due to oil lubricated gearbox





ECO.100S+CT

Watch our machines in action on:
www.youtube.com/euroboorby

Technical data	
Annular cutting	Ø 7/16" - 4"
Twist drilling	Ø 1/16" - 1 1/4"
Countersinking	Ø 3/8" - 4 1/8"
Tapping	Ø 1/8" - 1 3/16"
Milling	Ø 9/16"
Length	19 9/16"
Width	14 3/4"
Height	24 3/16" - 31 1/4"
Stroke	10 1/4"
Travel distance	X-axis 4 5/16" Y-axis 4 3/4"
Weight*	121 lbs
Magnet (l x w x h)	8 11/16" x 8 11/16" x 2 1/2"
Magnetic force	9,700 lbs
Motor power	17.3 A
Total power	18.6 A
Speed (no load)	I 42 - 110 rpm
	II 65 - 190 rpm
	III 140 - 400 rpm
	IV 220 - 620 rpm
Speed (load 17.3 A)	I 42 rpm
	II 65 rpm
	III 140 rpm
	IV 220 rpm
Spindle (Weldon)	MT3 1 1/4"
Voltage	110 - 120 V / 60 Hz

*Exclusive power cord and handles



Benefits

- Cross Table base to give dynamic positioning during drilling procedure over a range of 110 mm (x-axis) and 120 mm (y-axis)
- Milling feature to create slots and work on complex workpieces
- Switch to Tapping to create perfectly centered threads, while machine stays fixed on workpiece
- Strong dual coil CNC machined 2-way magnet, causing the machine to use less energy, generate less heat and therefore lasts longer
- Advanced safety features to reduce the risks of damaging the machine, tools, workpiece, armature, control unit(s) or hurting the operator
- Morse Taper 3 spindle with integrated tool cooling and lubrication
- Suitable for use in areas and workplaces where power supply is of less quality
- Timely service notification to avoid additional costs of unexpected downtime or unnecessary part replacement

Also suitable for mild milling

Features

Adjustable speed	Torque control	R/L rotation	Overheat protection
Power surge protection	Power fluctuation protection	Gyro-Tec	Automatic shut-off
Smart Restart	Oil lubricated gearbox	Carbon brush wear indicator	2-way magnet (TempTec)
Magnet LED-indicator (SensorTec)	Cross table	Milling	Tapping

Optimised motor efficiency and lifetime of key components due to oil lubricated gearbox



ECO.200S/T



Watch our machines in action on:
www.youtube.com/euroboorby

Technical data

Annular cutting	Ø 7/16" - 8"
Twist drilling	Ø 1/16" - 2"
Countersinking	Ø 3/8" - 8 1/16"
Tapping	Ø 1/8" - 1 7/8"
Length	20 1/4"
Width	10 7/16"
Height	25 9/16" - 35 5/8"
Stroke	10 1/16"
Weight*	129 lbs
Magnet (l x w x h)	13 3/4" x 4 15/16" x 2 9/16"
Magnetic force	8,113 lbs
Motor power	2,600 W (220 V)
Total power	17 A (110 V) 2,750 W (220 V)
Speed (no load)	I 40 - 80 rpm
	II 60 - 125 rpm
	III 145 - 300 rpm
	IV 230 - 470 rpm
Speed (load 23.6 A)	I 29 - 75 rpm
	II 46 - 120 rpm
	III 110 - 285 rpm
	IV 174 - 452 rpm
Spindle (Weldon)	MT4 1 1/4"
Voltage	110 - 120 V / 60 Hz
	220 - 240 V / 50 - 60 Hz

*Exclusive power cord and handles



Benefits

- Four-speed gearbox
- Integrated tool cooling and lubrication tank and fluid level indication
- Integrated safety strap and lifting shackle
- Progressive feed assist
- Morse Taper 4 spindle
- Strong triple coil CNC machined magnet
- Brushless technology

Features



Adjustable speed



Reverse rotation



Oil lubricated gearbox



Magnet LED-indicator (SensorTec)



Tapping

Optimised motor efficiency and lifetime of key components due to oil lubricated gearbox





Shallow Field (SF) magnet minimal requirements 3 mm

Unique design, unique usage

Drilling high-precision holes in steel tubes and pipes has always been a hassle. Until now! "Position and use" is what you expect of a portable power tool. Forget about the time consuming process of clamping all kinds of pipe adapters to your work piece.

Meet our TUBE-series, an innovative generation drilling machines specifically designed for drilling on curved material. By joining forces with Magswitch, technology leader in switchable magnetic technology, we have been able to develop a concept that instantly addresses, and

drastically improves work efficiency in the pipe industry. Not only will these help you save time. Its strong, powerful and sturdy design will also actively enable you to drill holes as fast as possible.



The magnets can be adjusted for the best position on round and flat surfaces. No extra accessories needed

Safe

Magnets do not require electrical power.

Light

The machines are extremely light.
 TUBE.30s+ - 22.7 lbs
 TUBE.55s+T - 35.3 lbs
 TUBE.55/AIR - 36.8 lbs

Strong

Maintains strong grip on thin steel. Minimal thickness of 1/8".

Easy to use

Automatically conform to any pipe Ø 3" or larger in diameter.

Efficient

One tool for flat or round surfaces without the need for expensive adapters – save time and money.



TUBE.30S+

Watch our machines in action on:
www.youtube.com/euroboorby

Technical data	
Annular cutting	Ø 1/2" - 1 3/16"
Twist drilling (Weldon)	Ø 1/16" - 1/2"
Countersinking (Weldon)	Ø 3/8" - 1 3/8"
Length	10 13/16"
Width	7 1/4"
Height	12 13/16" - 16 3/8"
Stroke	3 9/16"
Weight*	22.7 lbs
Magnet (l x w x h)	7 3/8" x 6 1/2" x 3 1/4"
Magnetic force	1,175 lbs
Min. material thickness	1/8"
Min. pipe diameter	3"
Motor power	8.2 A
Total power	8.6 A
Speed (no load)	I 775 rpm
Speed (load 8.2 A)	I 400 rpm
Spindle (Weldon)	3/4"
Voltage	110 - 120 V / 60 Hz

*Exclusive power cord and handles

Benefits

- The magnets can be adjusted for the best position on round and flat surfaces
- High-accuracy capstan hub
- Direct spindle drive and integrated tool cooling and lubrication
- Integrated slide for:
 - High accuracy
 - Enlarged lifecycle
 - Minimal vibration
- High-precision height adjustment for:
 - Low maintenance
 - Minimal wear correction
- Reversible handles: to enable you to change the operation side of the feed handles in confined spaces
- Reduced risk of damaging machine, tools and workpiece and hurting operator
- Suitable for use in areas and workplaces where power supply is of less quality
- Reduced risk of armature damage
- Reduced risk of control unit(s) damage
- Timely service notification to avoid additional cost by unexpected downtime or unnecessary part replacement
- Also available with electromagnetic magnet (page. 12)

Features



Power surge protection



Power fluctuation protection



Gyro-Tec



Automatic shut-off



Oil lubricated gearbox



Carbon brush wear indicator

Optimised motor efficiency and lifetime of key components due to oil lubricated gearbox





TUBE.55S+/T



Watch our machines in action on:
www.youtube.com/euroboorby

Technical data	
Annular cutting	Ø 1/2" - 2 3/16"
Twist drilling	Ø 1/16" - 15/16"
Countersinking	Ø 3/8" - 2 3/8"
Tapping	Ø 1/8" - 13/16"
Length	12 5/8"
Width	8 1/4"
Height	20 9/16" - 27 1/4"
Stroke	6 11/16"
Weight*	35.3 lbs
Magnet (l x w x h)	10 13/16" x 7 1/2" x 3 9/16"
Magnetic force	1,984 lbs
Full saturation as from	1/2"
Min. material thickness	1/8"
Min. pipe diameter	3 1/8"
Motor power	14.6 A
Total power	15.4 A
Speed (no load)	I 60 - 275 rpm
	II 100 - 500 rpm
Speed (load 14.6 A)	I 60 - 275 rpm
	II 100 - 500 rpm
Spindle (Weldon)	MT3 3/4"
Voltage	110 - 120 V / 60 Hz

*Exclusive power cord and handles



Benefits

- The magnets can be adjusted for the best position on round and flat surfaces
- Easily accessible carbon brushes. Motor will automatically shut-off in case of replacement
- High-accuracy capstan hub
- Morse Taper 3 spindle with integrated tool cooling and lubrication
- Integrated slide for:
 - High accuracy
 - Enlarged lifecycle
 - Minimal vibration
- High-precision height adjustment for:
 - Low maintenance
 - Minimal wear correction
- Reduced risk of damaging machine, tools and workpiece and hurting operator
- Suitable for use in areas and workplaces where power supply is of less quality
- Reduced risk of armature damage
- Reduced risk of control unit(s) damage
- Timely service notification to avoid additional cost by unexpected downtime or unnecessary part replacement
- Also available with electromagnetic magnet (page. 27)

Features

Adjustable speed	Reverse rotation	Overload protection	Overheat protection
Power surge protection	Power fluctuation protection	Gyro-Tec	Automatic shut-off
Smart Restart	Oil lubricated gearbox	Digital display	Carbon brush wear indicator
LED load indicators	Tapping		

Optimised motor efficiency and lifetime of key components due to oil lubricated gearbox





ECO.36+

Watch our machines in action on:
www.youtube.com/euroboorby

Technical data	
Annular cutting	1/2" - 1 7/16"
Twist drilling (Weldon)	1/16" - 9/16"
Countersinking (Weldon)	3/8" - 1 9/16"
In-corner drilling	0° 2" center to edge
	90° 2 1/16" center to edge
	45° 2 3/8" center to edge
Length	12 3/16"
Width	5 5/16"
Height	6 1/2"
Stroke	1 9/16"
Weight*	22.7 lbs
Magnet (l x w x h)	6 5/16" x 3 1/8" x 1 7/16"
Magnetic force	2,645 lbs
Motor power	9.5 A
Total power	10 A
Speed (no load)	I 700 rpm
Speed (load 9.5 A)	I 400 rpm
Spindle (Weldon)	3/4"
Voltage	110 - 120 V / 60 Hz

*Exclusive power cord and handle

Benefits

- One-speed gearbox
- User friendly Quick-Connect cutter fitment system
- Integrated carrying handle and safety strap attachment
- Left and right mount ability of detachable ratchet feed handle
- Integrated tool cooling and lubrication
- Removable and slideable safety guard
- Lubrication bottle with magnet attachment
- Strong dual coil CNC machined 2-way magnet, causing the machine to use less energy, generate less heat and therefore lasts longer
- Reduced risk of damaging machine, tools and workpiece and hurting operator
- Suitable for use in areas and workplaces where power supply is of less quality
- Reduced risk of armature damage
- Reduced risk of control unit(s) damage
- Timely service notification to avoid additional cost by unexpected downtime or unnecessary part replacement

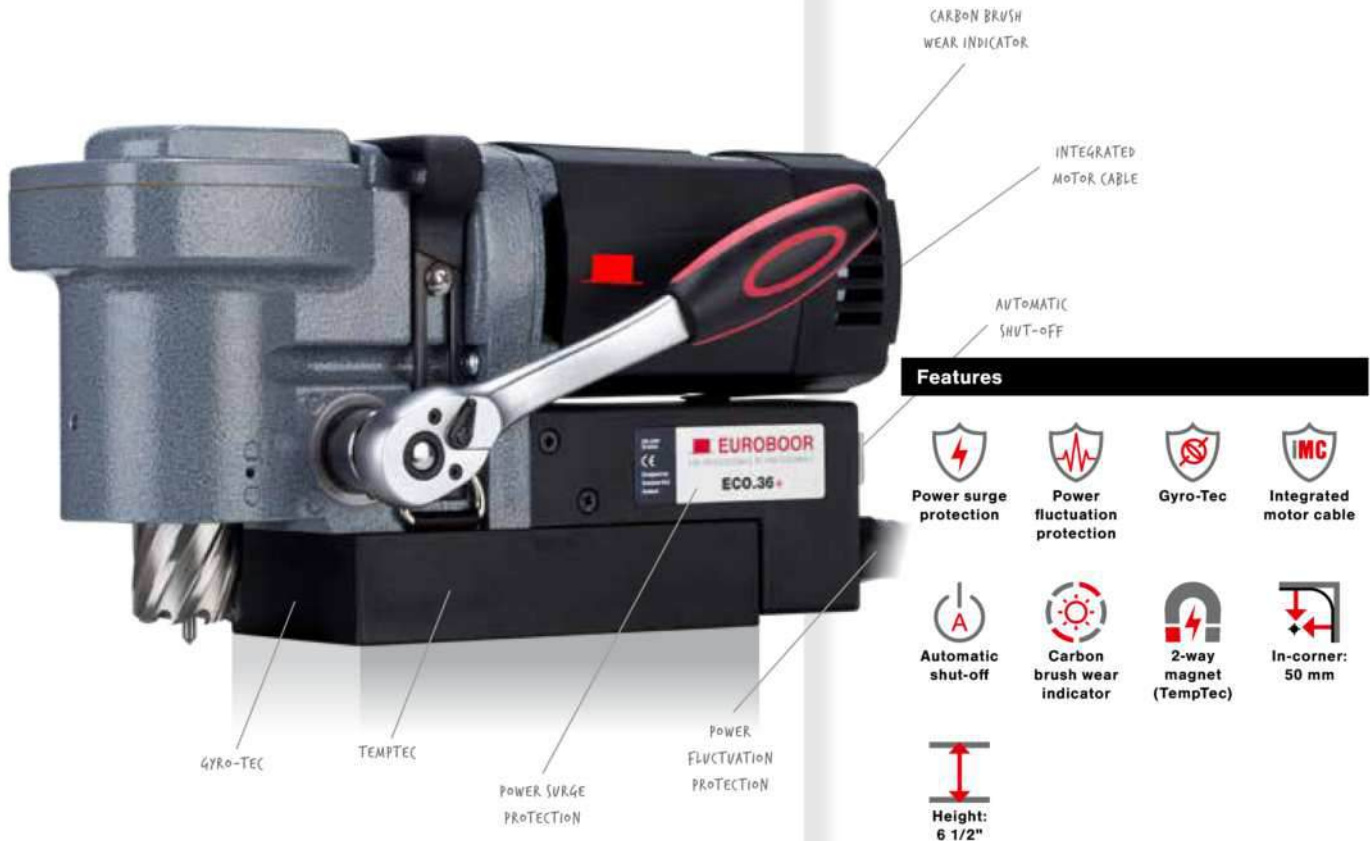

Features

Power surge protection	Power fluctuation protection	Gyro-Tec	Integrated motor cable
Automatic shut-off	Carbon brush wear indicator	2-way magnet (TempTec)	In-corner: 50 mm
Height: 6 1/2"			



ECO.36+ / T



Watch our machines in action on:
www.youtube.com/euroboorby

Technical data

Annular cutting	1/2" - 1 7/16"
Twist drilling (Weldon)	1/16" - 9/16"
Countersinking (Weldon)	3/8" - 1 9/16"
Tapping	1/8" - 1 3/9"
In-corner drilling	0° 2" center to edge
	90° 2 1/16" center to edge
	45° 2 3/8" center to edge
Length	12 3/16"
Width	5 5/16"
Height	6 1/2"
Stroke	1 9/16"
Weight*	22.7 lbs
Magnet (l x w x h)	6 5/16" x 3 1/8" x 1 7/16"
Magnetic force	2,645 lbs
Motor power	8.5 A
Total power	9 A
Speed (no load)	I 120 - 500 rpm
Speed (load 8.5 A)	I 120 - 400 rpm
Spindle (Weldon)	3/4"
Voltage	110 - 120 V / 60 Hz







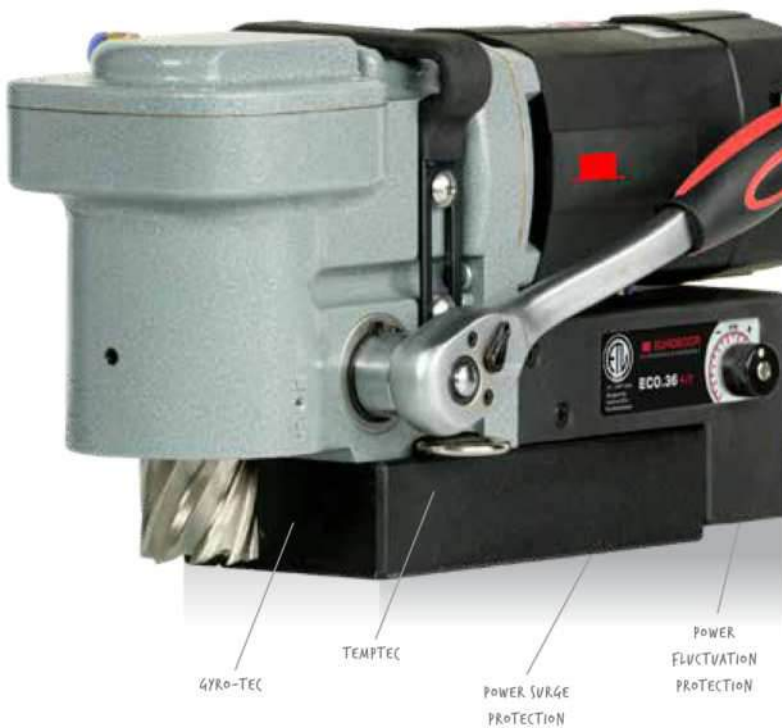



*Exclusive power cord and handle

Benefits

- One-speed gearbox
- User friendly Quick-Connect cutter fitment system
- Integrated carrying handle and safety strap attachment
- Left and right mount ability of detachable ratchet feed handle
- Integrated tool cooling and lubrication
- Removable and slideable safety guard
- Lubrication bottle with magnet attachment
- Strong dual coil CNC machined 2-way magnet, causing the machine to use less energy, generate less heat and therefore lasts longer
- Reduced risk of damaging machine, tools and workpiece and hurting operator
- Suitable for use in areas and workplaces where power supply is of less quality
- Reduced risk of armature damage
- Reduced risk of control unit(s) damage
- Timely service notification to avoid additional cost by unexpected downtime or unnecessary part replacement



Features

 Reverse rotation	 Power surge protection	 Power fluctuation protection	 Gyro-Tec
 Integrated motor cable	 Automatic shut-off	 Carbon brush wear indicator	 2-way magnet (TempTec)
 In-corner: 50 mm	 Height: 6 1/2"		



F16+



Watch our machines in action on:
www.youtube.com/euroboorby

Technical data	
Twist drilling	Ø 1/16" - 5/8"
Length	12 3/16"
Width	6 11/16"
Height	12 13/16" - 19 1/2"
Stroke	6 11/16"
Weight**	16.5 lbs
Magnet (l x w x h)	6 5/16" x 3 1/8" x 1 7/16"
Magnetic force	2,645 lbs
Voltage	110 - 120 V / 60 Hz

*Hand drill dependable
 **Exclusive power cord and handles



Mounted hand drilling machine not included.

Benefits

- Perfect solution for high-precision small diameter drilling tasks
- 43 mm Euro collar connection (33 mm and 38 mm filler rings included)
- Safe and easy rear mounted socket
- High-accuracy capstan hub
- High-precision height adjustment for:
 - Low maintenance
 - Minimal wear correction
- Strong dual coil CNC machined 2-way magnet causing the machine to use less energy, generate less heat and therefore lasts longer
- Reversible handles: to enable you to change the operation side of the feed handles in confined spaces
- Reduced risk of damaging machine, tools and workpiece and hurting operator
- Suitable for use in areas and workplaces where power supply is of less quality
- Reduced risk of armature damage
- Reduced risk of control unit(s) damage
- No unexpected downtime or unnecessary part replacement

Features

- Power surge protection
- Power fluctuation protection
- Gyro-Tec
- 2-way magnet (TempTec)
- Magnet LED-indicator (SensorTec)



VAC.50S+



Watch our machines in action on:
www.youtube.com/euroboorby

Technical data

Annular cutting

- steel and hard metals	Ø 7/16" - 1 3/16"
- other metals and plastic	Ø 7/16" - 2"

Twist drilling

- steel and hard metals	Ø 7/16" - 2"
- other metals and plastic	Ø 1/16" - 15/16"

Countersinking

Length	16 15/16"
Width	7 1/2"
Height	16 17/32" - 23 7/32"
Stroke	6 11/16"
Weight*	21.8 lbs
Magnet (l x w x h)	11 13/16" x 5 1/2" x 13/16"
Adsorption force	661 lbs

Vacuum motor (integrated)

- Air flow	0.53 cfm
- Gauge pressure	-11.6 psi
- Power	1 A
- Voltage	12 V
Motor power	11.4 A
Total power	11.8 A

Speed (no load)	I	380 rpm
	II	690 rpm
Speed (load 11.4 A)	I	235 rpm
	II	415 rpm
Spindle (Weldon)	MT3 3/4"	
Voltage	110 - 120 V / 60 Hz	

*Exclusive power cord and handles

Benefits

- High-accuracy capstan hub
- Morse Taper 3 spindle with integrated tool cooling and lubrication
- Integrated slide for:
 - High accuracy
 - Enlarged lifecycle
 - Minimal vibration
- High-precision height adjustment for:
 - Low maintenance
 - Minimal wear correction
- Vacuum technology for almost all (magnetic and non-magnetic) smooth surfaces
- Reduced risk of damaging machine, tools and workpiece and hurting operator
- Suitable for use in areas and workplaces where power supply is of less quality
- Reduced risk of armature damage
- Reduced risk of control unit(s) damage
- Timely service notification to avoid additional cost by unexpected downtime or unnecessary part replacement

**Ideal for non magnetic materials like:
 stainless steel,
 aluminum, plastics etc.**



Features



Power surge protection



Vacu-Tec



Integrated motor cable



Automatic shut-off



Oil lubricated gearbox



Carbon brush wear indicator



Vacuum LED-indicator

Optimised motor efficiency and lifetime of key components due to oil lubricated gearbox



EBM.360



Watch our machines in action on:
www.youtube.com/euroboorby

Technical data	
Annular cutting	Ø 1/2" - 1 7/16"
Twist drilling	Ø 1/16" - 1/2"
Countersinking	Ø 3/8" - 1 9/16"
Length	11 11/16"
Width	4 7/16"
Height	16 9/16" - 24"
Stroke	9 1/16"
Weight*	25.8 lbs
Magnet (l x w x h)	6 5/16" x 3 1/8" x 1 5/8"
Magnetic force	3,750 lbs
Motor power	35.1 A DC
Total power	36.5 A DC
Speed (no load)	I 506 rpm
Speed (load 35.1 A DC)	I 375 rpm
Spindle (Weldon)	3/4"
Power source	37 V Battery 2.6 Ah li-ion

*Exclusive handles



Benefits

- Powerful battery with charger
- Powerful high-torque DC motor
- Multi-level electronic protection for optimal safety
- Extremely short battery charging time
- Detachable spindle and integrated tool cooling and lubrication
- High-precision height adjustment for:
 - Low maintenance
 - Minimal wear correction
- Strong dual coil CNC machined magnet



From 0% to 75% battery charge in 17 minutes! Battery charge 75% to 100% takes 58 minutes. Fully charged in 75 minutes.

EBM.36/P-18V



Watch our machines in action on:
www.youtube.com/euroboorby

Technical data

Annular cutting	Ø 7/16" - 1 7/16"
Twist drilling	Ø 1/16" - 1/2"
Countersinking	Ø 3/8" - 1 9/16"
Length	12 13/16"
Width	9 1/4"
Height	14 9/16" - 16 1/8"
Stroke	5 1/2"
Weight (incl. batt)*	22.4 lbs
Magnet (l x w x h)	6 3/16" x 3 3/8" x 1 3/4"
Magnetic force	
Min. material thickness	1/4"
Speed (no load)	530 rpm
Speed (load)	430 rpm
Spindle (Weldon)	3/4"
Battery capacity	18 V 5 Ah Li-ion, 18 V 9 Ah Li-ion

*Exclusive handles



Benefits

- Battery-powered motor system
- Integrated carrying handle and safety strap attachment
- Compact and lightweight design
- Based on Makita LXT 18V battery platform
- Integrated tool cooling and lubrication
- Brushless technology

Magnet benefits

- Permanent, non-electric monobloc magnet system
- No loss of magnetic grip in case of electric power cuts or fluctuations
- Powerful hold, even on thinner steel

Features



Battery operated



Permanent magnet



Brushless motor



Makita LXT 18V platform



Magnet LED-indicator (SensorTec)

Accessories EBM.36/P-18V



Batteries 5Ah and 9Ah
EB5A, EB9A



Charger
EBC1

AIR.55



Watch our machines in action on:
www.youtube.com/euroboorby

Technical data

Annular cutting	Ø 7/16" - 2 1/16" (HSS) Ø 7/16" - 2 3/16" (TCT)
Twist drilling	Ø 1/16" - 15/16"
Countersinking	Ø 7/16" - 2 3/16"
Length	14 15/16"
Width	9 5/8"
Height	24 3/16" - 27 3/4"
Stroke	6 9/16"
Weight*	36.4 lbs
Magnet (l x w x h)	7 3/16" x 3 15/16" x 2 3/16"
Magnetic force	1,984 lbs
Speed (no load)	380 rpm
Spindle (Weldon)	MT3 3/4"
Power source	Air, min. 6.3 bar, max. 8 bar, consumption 1.1 m ³ /min

*Exclusive handles



Benefits

- Air-powered motor system
- Powerful, spark-free, explosion-safe motor
- Single operation knob for magnet and motor with 'deadman's' control
- Large 167 mm stroke
- Automatic, integrated lubrication and cooling system
- Anti-static construction
- Safety guard
- Also available with permanent tube magnet for both pipe and flat material (page. 48)

Magnet benefits

- Permanent, non-electric monobloc magnet system
- No loss of magnetic grip in case of electric power cuts or fluctuations
- Powerful hold, even on thinner steel thicknesses

Features



Air motor:
min 6.3 bar
(90 PSI)



Atex

TUBE.55/AIR



Watch our machines in action on:
www.youtube.com/euroboorby

Technical data

Annular cutting	Ø 7/16" - 2 1/16" (HSS) Ø 7/16" - 2 3/16" (TCT)
Twist drilling	Ø 1/16" - 15/16"
Countersinking	Ø 7/16" - 2 3/16"
Length	13 9/16"
Width	9 5/8"
Height	24 13/16" - 28 3/4"
Stroke	6 9/16"
Weight*	36.8 lbs
Magnet (l x w x h)	10 13/16" x 7 1/2" x 3 9/16"
Magnetic force	1,984 lbs
Full saturation as from	1/2"
Min. material thickness	1/8"
Min. pipe diameter	3 1/8"
Speed (no load)	380 rpm
Spindle (Weldon)	MT3 3/4"
Power source	Air, min. 6.3 bar, max. 8 bar, consumption 1.1 m ³ /min

*Exclusive handles



Benefits

- Air-powered motor system
- The magnets can be adjusted for the best position on round and flat surfaces
- Powerful, spark-free, explosion-safe motor
- Large 167 mm stroke
- Automatic, integrated lubrication and cooling system
- Anti-static construction
- Also available with permanent base magnet (page. 53)

Magnet benefits

- Permanent, non-electric magnet system
- No loss of magnetic grip in case of electric power cuts or fluctuations
- Flexible dual magnet array which automatically adjust to the geometry of the workpiece
- Powerful hold, even on thinner steel thicknesses

Features



Air motor:
min 6.3 bar
(90 PSI)



Atex

Accessories

We are convinced accessories are auxiliary tools. Their development follows from practical situations in which challenges and problems present themselves; problems which could have been prevented by properly estimating the diversity and complexity of the work.

After more than 40 years of practical experience we dare to say we are familiar with most challenges that you may encounter. Euroboor accessories have been developed for direct practical solutions and comfort at work. Non-magnetic base, horizontal drilling or lack of space, you can proceed undisturbed at all times.

Our accessories are professional solutions that are specifically designed for and tuned to your activities.

Practical solutions for comfort at work



“Our vision is focused on developing accessories that add value and facilitate you in your daily work”.

Weldon setup overview

— Absolute connection Optional connection

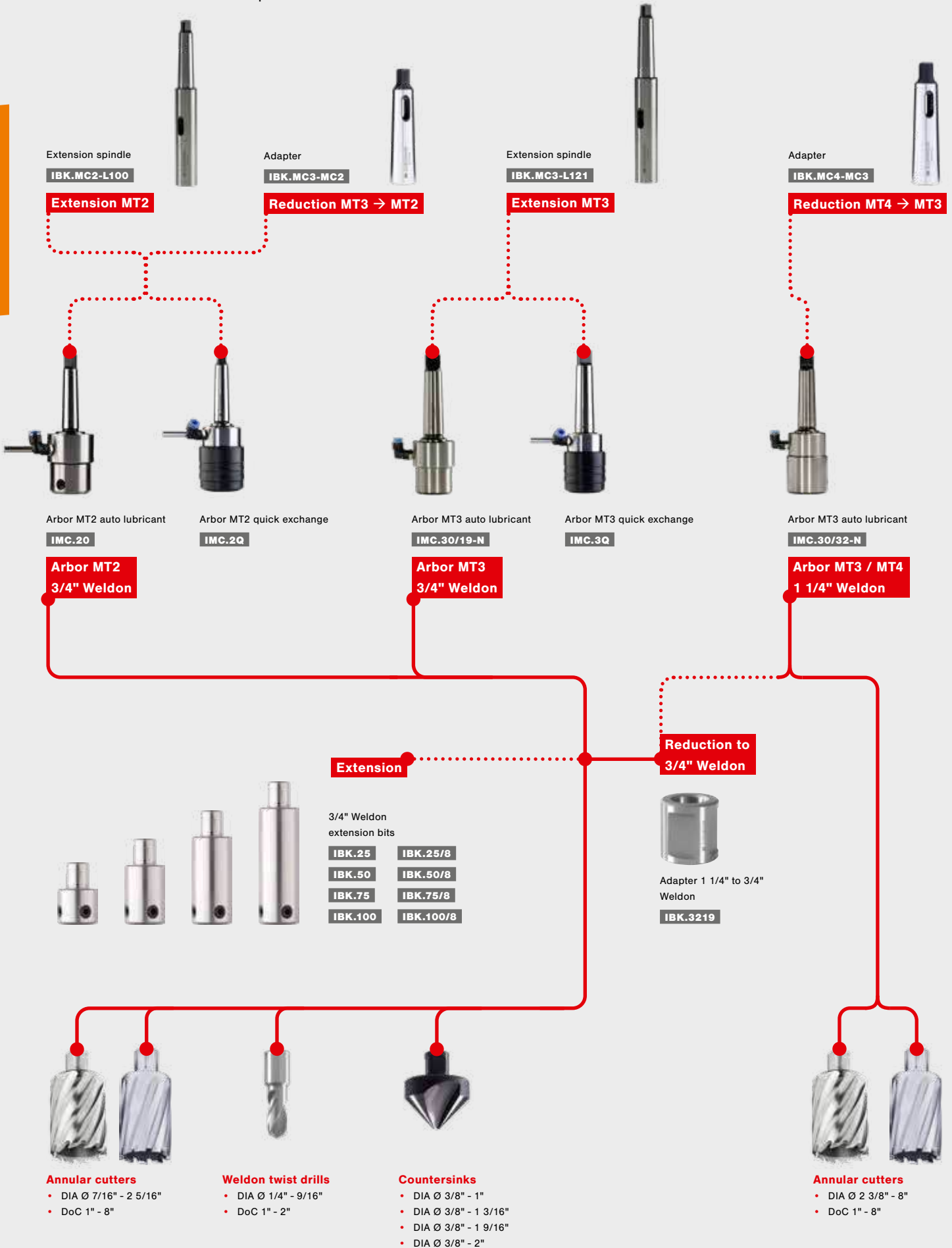

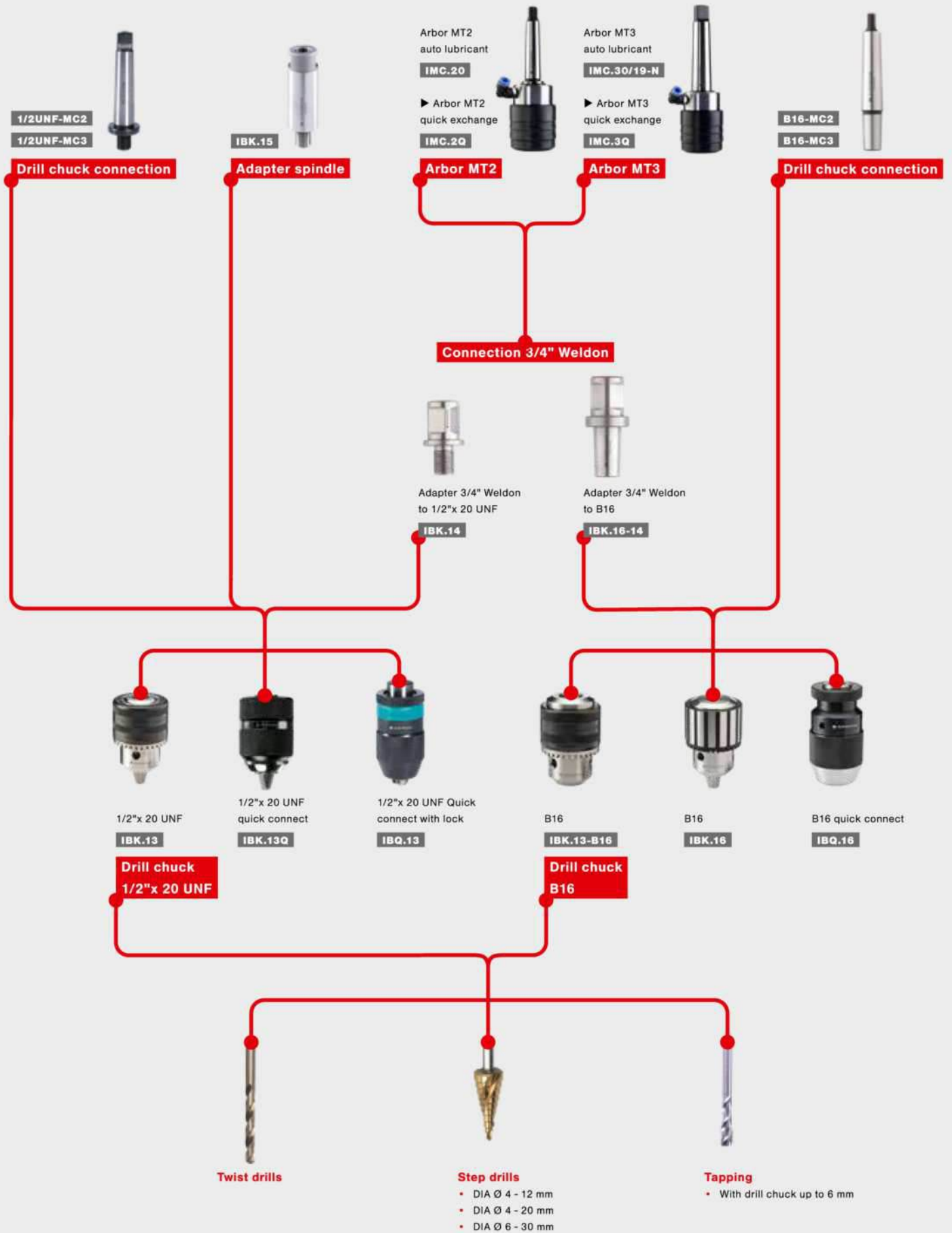



EUROBOOR
FOR PROFESSIONALS BY PROFESSIONALS

Armature kit
Original Euroboor Parts

Armature kit

The armature kit consists of original parts for the maintenance of your magnetic core drill. We therefore recommend that you only use this official Euroboor kit to maintain your machine warranty. There is a suitable armature kit for all Euroboor magnetic core drilling machines.



Total package

The use of all spare parts from this total package ensures that the lifespan of your magnetic drilling machine can be extended by factor four to five. In addition, hidden maintenance costs are kept to a bare minimum and you maintain your machine warranty. After maintenance with the armature kit, the magnetic drilling machine operates as new again.

The armature kit with original Euroboor spare parts consists of:

- Armature
- Bearing(s)*
- Circlip
- First gear
- Carbon brush set

ARM-KIT

* Depending on machine the number and type of bearings may vary.

Pipe Adapter kit

- Suitable for tube diameter from \varnothing 2" up to 19 11/16"
- Suitable for all Euroboor magnetic drilling machines (except ECO.200S/T & TUBE-series)
- Suitable for almost all drilling machines in the market (for universal use)

Dimensions PAK.250

Length: 11 1/4"
 Width: 10 9/16"
 Height: 3 3/4"

Dimensions inside plate

Length: 10 9/16"
 Width: 4 7/16"
 Height: 9/16"

Weight

27.5 lbs

PAK.250



WelNit kit

- The WelNit Kit gives you the possibility to connect every type of cutter with you Magnetic Drilling Machine
- The One Touch Arbor gives you the advantage of fast and save cutter changes. The cutter has a tight fit which gives you less vibrations during the cutting process
- For every cutter length you have the right pilot pin in the box
- Packed in luxury case

The WelNit kit consists of:

- **Morse taper Nitto:** morse taper for placement in a Core drilling machine and the use of a Nitto One-Touch
- **Adapter one-Touch Nitto-3/4" Weldon:** adapter to place a drill with Weldon recording in a drill with Nitto one Touch recording. Includes 6 mm hole for a Pilot pin
- **Adapter one-Touch Nitto-3/4" Weldon:** adapter to place a drill with Weldon recording in a drill with Nitto one Touch recording. Includes 8 mm hole for a Pilot pin
- **Adapter 19.05 mm WelNit - 1/2" x 20 UNF:** adapter to place a drill head with 20 UNF connection in a drill with Nitto one Touch connection
- **Drill chuck quick change 13mm 1/2" x 20 UNF:** drill head for the use of twist drills with a round or 3 flat shank up to 13 mm
- **9 different pilot pins** for placing the drill in the correct position and pushing out the slug:
 \varnothing 6.35 x 90 mm, \varnothing 6.35 x 102 mm, \varnothing 6.35 x 120 mm,
 \varnothing 6.35 x 127 mm, \varnothing 6.35 x 155 mm, \varnothing 8.0 x 103 mm,
 \varnothing 8.0 x 122 mm, \varnothing 8.0 x 128 mm, \varnothing 8.0 x 165 mm



Content MC3 kit:

- IMC.3 NITTO
- IBK.NIT
- IBK.NIT/8
- IBK.14/NIT
- IBQ.13
- IBC.75
- IBC.80
- IBC.90
- IBC.100
- IBC.130
- IBC.K25
- IBC.K50
- IBC.128
- IBC.120

WELNIT-KIT.MC3

Content MC2 kit:

- IMC.2 NITTO
- IBK.NIT
- IBK.NIT/8
- IBK.14/NIT
- IBQ.13
- IBC.75
- IBC.80
- IBC.90
- IBC.100
- IBC.130
- IBC.K25
- IBC.K50
- IBC.128
- IBC.120

WELNIT-KIT.MC2

Extensions



Extension Weldon 1"

3/4" Weldon, 1" extension, outer Ø 1 3/8"
For 1/4" pilot pins

IBK.25

For 5/16" pilot pins

IBK.25/8

Extension Weldon 2"

3/4" Weldon, 2" extension, outer Ø 1 3/8"
For 1/4" pilot pins

IBK.50

For 5/16" pilot pins

IBK.50/8

Extension Weldon 2 15/16"

3/4" Weldon, 2 15/16" extension,
outer Ø 1 3/8"
For 1/4" pilot pins

IBK.75

For 5/16" pilot pins

IBK.75/8

Extension Weldon 3 15/16"

3/4" Weldon, 3 15/16" extension,
outer Ø 1 3/8"
For 1/4" pilot pins

IBK.100

For 5/16" pilot pins

IBK.100/8

MT2 - 100 mm

extension

MT2 - MT2

IBK.MC2-L100

MT3 - 250 mm

extension

MT3 - MT3

IBK.MC3-L250

MT3 - 121 mm

extension

MT3 - MT3

IBK.MC3-L121

MT3 - 450 mm

extension

MT3 - MT3

IBK.MC3-L450



Extreme Thin Extension Weldon 4"

3/4" Weldon, 4" extension, outer 1 1/32"
For 1/4", 5/16" pilot pins

IBK.100/CK

Extreme Thin Extension Weldon 6"

3/4" Weldon, 6" extension, outer 1 1/32"
For 1/4", 5/16" pilot pins

IBK.150/CK

Extreme Thin Extension Weldon 8"

3/4" Weldon, 8" extension, outer 1 1/32"
For 1/4", 5/16" pilot pins

IBK.200/CK



Connections



Adapter Nitto One Touch

(external) to 3/4" Weldon (internal)

IBK.NIT



Adapter Fein Quick-In

(external) to 3/4" Weldon (internal)

IBK.QFN



Adapter 19.05 mm Weldon

(external) to 1/2" x 20 UNF

IBK.14



Adapter 3/4" Weldon

(external) to B16 drill chuck
connection

IBK.16-14



Reduction ring

1 1/4" Weldon (external)
to 3/4" Weldon (internal)

IBK.3219

Morse Taper reductions



Morse Taper reduction

MT3 (machine)
to MT2 (tool holder)

IBK.MC3-MC2



Morse Taper reduction

MT4 (machine)
to MT3 (tool holder)

IBK.MC4-MC3

Arbors



Auto Arbor IMC.2Q / IMC.3Q

MC.2 / MC.3

Arbor MT2 - 3/4" Weldon
For cutters Ø 12 - 60 mm

MC.2

Arbor MT2 - 3/4" Weldon
Including lubrication ring

IMC.20

Auto Arbor MT2 - 3/4" Weldon
Including lubrication ring
Quick exchange, Weldon connection

IMC.2Q



MC.3/32

Arbor MT3 - 3/4" Weldon
For cutters Ø 7/16" - 2 3/8"

MC.3

Arbor MT3 - 3/4" Weldon
For cutters Ø 7/16" - 2 3/8"
With extended shaft, including lubrication ring

MC.3-75

Arbor MT3 - 3/4" Weldon
Including lubrication ring

IMC.30/19-N

Auto Arbor MT3 - 3/4" Weldon
Including lubrication ring
Quick exchange, Weldon connection

IMC.3Q



IMC.30/19-N / IMC.30/32-N

Arbor MT3 - 1 1/4" Weldon
For cutters Ø 2 7/16" - 8"

MC.3/32

Arbor MT3 - 1 1/4" Weldon
Including lubrication ring

IMC.30/32-N

Arbor MT4 - 1 1/4" Weldon
Including lubrication ring

IMC.40/32

Arbor MT4 - 1 1/4" Weldon
Including lubrication ring

ECO200.MC4/32



Nitto 2 / 3

Arbor Nitto MT2 - 3/4" Weldon
For Nitto cutters, Including lubrication ring

IMC.2 NITTO

Arbor Nitto MT3 - 3/4" Weldon
For Nitto cutters, Including lubrication ring

IMC.3 NITTO

Adapter 1/2" x 20 UNF (external) to 1/2" x 20 UNF
(internal) extension adapter for drill chucks fitting length
65 mm

IBK.15



Assembly of a shorter extension adapter IBK.15 for use with drill chucks.

Benefit:
increases space
for twist drills

IBK.15 with a
drill chuck IBQ.13Q
for illustration purpose

Drill chuck connections



Morse Taper 2 to B16
Spindle connection
B16-MC2



Morse Taper 3 to B16
Spindle connection
B16-MC3



Morse Taper 2 to 1/2" x 20 UNF
Spindle connection
1/2UNF-MC2



Morse Taper 3 to 1/2" x 20 UNF
Spindle connection
1/2UNF-MC3

Morse Taper 2 to B18
Spindle connection
B18-MC2

Morse Taper 3 to B18
Spindle connection
B18-MC3

Twist drill chucks



Drill chuck
DIA Ø 1/6" - 1/2",
1/2" x 20 UNF connection
IBK.13



Drill chuck quick connect
DIA Ø 1/6" - 1/2"
1/2" x 20 UNF connection
Keyless
IBK.13Q



Drill chuck
DIA Ø 1/6" - 1/2"
B16 connection
IBK.13-B16



Drill chuck
DIA Ø 1/6" - 5/8"
B16 connection
IBK.16



Drill chuck quick connect
DIA Ø 1/6" - 1/2"
1/2" x 20 UNF connection
Keyless
IBQ.13



Drill chuck quick connect
DIA Ø 1/6" - 5/8"
B16 connection
Keyless
IBQ.16

The IBQ.13 and IBQ.16 Quick connect drill chucks are keyless, three-jaw, self-centering chucks that hold drill bits in place during drilling tasks. They can be used with magnetic drilling machines together with Euroboor accessories like IBK.14, IBK.15 and 1/2" x 20 UNF Morse Taper.

Cutting lubricants

Euroboor spends a lot of time and effort on pushing boundaries to make your drilling process far more efficient. This continuous research and development is reflected in superior quality magnetic drilling machines, annular cutters and all other kinds of tools and accessories. While this lays the basis for optimum drilling and cutting performance, there is also the hugely important, often underestimated, factor of proper cooling and lubrication.

However sharp, stable or fast a cutting tool may be, working with metal is a demanding job which generates friction and heat, impacting end result, processing time and durability.

Lubrication

A suitable lubricant will reduce friction greatly. The tool will set itself much better and will generate less vibrations. A smoother operation means less power needs to be put into the job, the finished result will be more precise and operation time can be reduced by up to 30%.

Cooling

Processing metals can, as generally known, produce a lot of heat. Overheating can have serious negative effects on the behaviour of the workpiece and tool, and thus the overall performance. The result is generally an increased processing time, but not being

able to complete the job might even be possible as well. Inappropriate cooling can lead to specific issues, such as unreliable slug ejection when working with annular cutters.

Protection

For example, think about the discolouration of your metal workpiece or about the sizing accuracy of drilled holes after cooling down. When pushing your cutting tools fast and hard, burning them up might even be possible quicker than you would have imagined. With the use of appropriate lubrication and cooling you are able to actively protect the workpiece and used tools.

Durability

Making sure a cutting tool is able to perform smoothly and constantly by proper cooling and lubrication will increase its

functional life significantly. Taking annular cutting as an example, both the drilling machine and cutter will benefit from the drastically reduced stress. Depending on circumstances, an annular cutter can last up to 5 times longer when properly taken care of during operation!

Our offering

Euroboor offers a wide range of well-considered cooling and lubrication products to match your requirements. If you are processing high-tensile strength stainless steel or need to cut a plain aluminium bar, create large-bore holes or prepare a fine-coarse thread, whether working on a drilling line or in difficult spots on location, we can help you out with just the right lubricant.

The use of appropriate cutting lubricant adds value to your business operation

- Higher quality workpiece finishing
- Minimised tool wear and replacement
- Reduced processing time & lower operation cost

Material application		● Optimal ● Good ● Possible													
Oil	Material	Plastics GRP/ CRP	Brass, Copper, Tin	Grey cast iron	Steel					Stainless steel		Aluminium		Exotic mate- rials*	Rails
					< 500N	< 750N	< 900N	< 1,100N	< 1,400N	< 900N	≤ 900N	< 10% Si	≤ 10% Si		
IBO.10		○	○	○	●	●	●	●	●	○	○	○	○	○	○
IBO.P911		○	○	○	●	●	●	●	●	○	○	○	○	○	○
IBO.20		○		●	○	○	○	○	○	●	●			●	●
IBO.50		○	●	○	○	○	○	○	○	○	○	●	●	○	○
IBO.60		○	○	○	●	●	●	●	●	○	○	○	○	○	○
MV.4		○	○	○	●	●	●	●	●	○	○	○	○	○	○
IBO.30		○	○	○	●	●	●	●	●	○	○	○	○	○	○
IBP.70				●	●	●	●	●	●	●	●			●	●

This overview only offers an indication of use. Further information on lubrication and material behaviour on request. Always try the chosen cutting lubricant on a test piece first.

* Inconnell, Nimonic, HARDOX and Hastelloy

Cutting oils, sprays, paste and gearbox oil

General usage

IBO.10

Mild steel lubricating and cooling cutting oil

General cutting oil offering premium cooling and lubrication for most common mild steel projects. High-cutting power tool preservation and improved processing times.

IBO.1001 (1 litre)

IBO.1050 (5 liters)



MV.4

All metals lubricating and cooling concentrate

User and environmentally friendly water-soluble cooling and lubricating concentrate. Particularly suitable for automatic dosing systems, offering efficient cooling on the majority of metal workpieces. No harmful mist formation and economical in use (can be diluted up to 1:20 ratio).

MV.4001 (1 litre)

MV.4050 (5 liters)



Specialised usage

IBO.20

Inox, chromium and nickel lubricating and cooling cutting oil

Heavy duty cutting oil with extremely efficient lubricating and cooling properties, solely for use on hard (plated) materials such as stainless steel, chromium and nickel. Drill up to two times faster, while minimising the chance of burnt tool bits and discoloured workpieces.

IBO.2001 (1 litre)

IBO.2050 (5 liters)



IBO.50

Non-ferrous metals cutting oil

Mild paraffin-based mineral oil with excellent lubricating possibilities for softer, non-ferrous, metals such as aluminium, copper and zinc. Highly effective in preventing discoloration and deformation of the workpiece and enhancing drilling performance.

IBO.5001 (1 litre)

IBO.5050 (5 liters)



IBO.60

Tapping and threading oil

Universal non-staining cutting oil, specifically for tapping and threading. Offers consistent lubrication and enhances the precision of your operation. The unique properties actively help chip clearance and keep your tools sharp.

IBO.6001 (1 litre)

IBO.6050 (5 liters)





IBO-P.911

Mild steel lubricating and cooling cutting oil spray

Premium metal processing cooling and lubrication in spray can form, suitable for use on mild steel. Highly versatile in use and ideal for tool preparation.

IBO-P.911.500 (500 ml)



IBO.30

All metals lubricating and cooling cutting oil spray

Versatile spray with high-cooling and evaporation properties. Ideal for the (after) cooling of all workpieces and tools. The minimal harmful contents and minimal greasy residue facilitate further proceedings with the workpiece.

IBO.30 (500 ml)

IBP.70

High-alloy steel cutting paste

A cutting compound for metal, with strong adhesive strength on materials and tools, for vertical and upside down applications where liquid metal working oils can't be used. Based on mineral oil with carefully selected extreme pressure additives with excellent lubricating properties for low tool wear and excellent surface quality. Suitable for drilling, milling, tapping, threading and punching of high-alloy steel grades.

IBP.70 (1 liters)



Gearbox oil

IBO.G1

Offered as official Euroboor spare part, IBO.G1 is the recommended oil for Euroboor magnetic drilling machines with oil lubricated gearboxes. This is the only gear lubricant which is able to meet our high-requirements for operating temperature, minimal wear and high-machine efficiency.

For use with:

ECO.30S+, ECO.40S, ECO.40S+, ECO.50S, ECO.50S+, ECO.55S/T, ECO.55S+/T, ECO.55S+/TA, ECO.60S, ECO.60S+, ECO.80S+, ECO.100S+/T, ECO.100S+/TD, TUBE.30S+ and TUBE.55S/T, TUBE.55S+/T.

IBO.G101 (1 litre)



Multifunctional oil spray



Operational use:

- Rust removing
- Lubricating
- Contact improving
- Cleaning
- Corrosion protective
- Moisture repellent

IBO.40

Universal problem solving and preventing spray, suitable for the maintenance of tools and other moving parts. Also suitable as protector of electronics. Does not contain silicones, water or graphite.

IBO.40 (400 ml)



Euroboor

Annular cutters

Annular cutters

- + Longer lifespan
- + Exact dimensions
- + Unique teeth geometry
- + Optimum chip clearance
- + Superior slug ejection



High-precision shanks, various connections



Weldon 3/4"



WelNit 3/4"



Weldon 1 1/4"

Pilot pins

Pilot pins are essential for the use of annular cutters, as they provide the following practical uses:

- Centration of cutter
- Control of oil flow
- Slug ejection



1. Pilot pin
2. Annular cutter
3. Pilot pin inside annular cutter
4. Place in arbor magnetic drilling machine and commence drilling



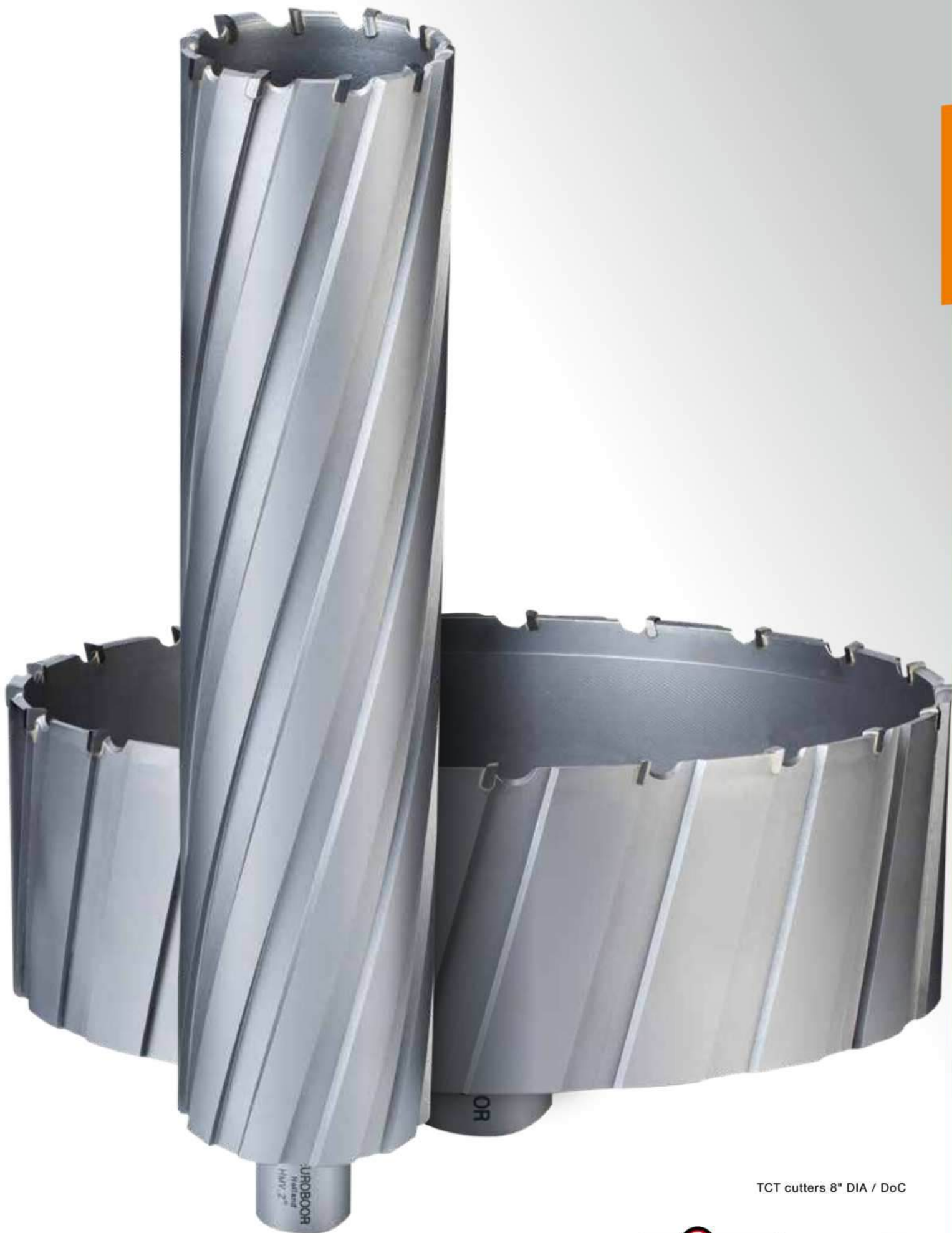

TCT cutters 8" DIA / DoC

Euroboor annular cutter portfolio

Geometry

Altering cutting teeth angles for precise and clear cuts

On our HSS and TCT cutters every tooth does its own job, working together to cut cleaner and quicker. They actually save time!



TCT cutters have three different teeth



HSS cutters have two different teeth

Did you know?

- With the **right lubrication** tool life is drastically improved;
- Drilling with cutters is best with **internal cooling**;
- A **perfect fitting pilot pin** prevents cutter breakage;
- **TCT cutters need a higher speed** than HSS cutters;
- Euroboor HSS cutters have an extra landing on the outside and cut more accurate with **less friction**;
- Euroboor cutters have a grounded inside **which offers expansion room to slug**;
- Metric & imperial **specific sizes and shank variations** can be supplied on request.

Weldon shank



Shank

Euroboor annular cutters are standard equipped with **high-precision Weldon shanks**. Depending on the cutter size and specification; 3/4" or 1 1/4".

Additionally we also offer cutters with double shank design. These annular cutters have an increased practical application, as they are suitable for use on machinery requiring Weldon fitment as well as machinery with Nitto fitment.

WeiNit shank



The No. 1 choice in HSS, HSS-Cobalt and TCT

We offer a well-considered range of annular cutters, designed to exceed your requirements. Many years of our hands-on experience are reflected in the unique features of our cutters. We do not compromise on quality and for that reason our cutters are appreciated worldwide for optimum performance, durability and longer functional life in all industries. From small scale fabrication to the oil and shipping industry, and from large scale fabrication to construction, and beyond.



Annular cutter overview

Depth of Cut (DoC)				Ø Imperial (inch) Weldon	Ø Imperial (inch) WelNit	Ø Metric (mm) Weldon	Ø Metric (mm) WelNit
1"	30 mm	HSS		7/16" - 4"	7/16" - 2 1/4"	12 - 25	-
1"	30 mm	HSS-Cobalt	8%	7/16" - 3"	-	-	-
1"	35 mm	TCT		7/16" - 3"	7/16" - 2 5/16"	12 - 20	-
2"	55 mm	HSS		7/16" - 4"	7/16" - 2 1/4"	12 - 67	-
2"	55 mm	HSS Stack		3/4" - 1 1/4"	-	-	-
2"	55 mm	HSS-Cobalt	8%	7/16" - 2 7/8"	-	-	-
2"	55 mm	TCT		7/16" - 8"	7/16" - 2 5/16"	12 - 200	18 - 39
3"	75 mm	HSS Stack		3/4" - 1 1/4"	-	-	-
3"	75 mm	HSS-Cobalt	8%	3/4" - 1 7/8"	-	-	-
3"	75 mm	TCT		7/16" - 3"	11/16" - 2 1/8"	39 - 40	-
4"	100 mm	TCT		7/16" - 8"	11/16" - 3 13/16"	36 - 100	-
6"	150 mm	TCT		7/8" - 2"	11/16" - 1 15/16"	-	-
8"	200 mm	TCT		7/8" - 2"	13/16" - 3 13/16"	-	-

Material appliance		● Optimal ○ Good ○ Possible													
Cutter	Material	Plastics GRP/ CRP	Brass, Copper, Tin	Grey cast iron	Steel					Stainless steel		Aluminium		Exotic materials*	Rails
					< 500N	< 750N	< 900N	< 1,100N	< 1,400N	< 900N	≤ 900N	< 10% Si	≤ 10% Si		
HSS		●	○		●	●	○					○			
HSS-Cobalt		●	●	○	●	●	●	○	○	○	○	●	○	○	
TCT			○	●	●	●	●	●	●	●	●	●	●	●	○

* Inconnell, Nimonic, HARDOX, Hastelloy

Annular cutter

High Speed Steel



HSS annular cutters, with unique teeth geometry, provide clear cutting, fast feed rate, less vibration, smooth hole surface and long tool life. They are better and quicker than twist drills. HSS annular cutters can be used on all kinds of magnetic drilling machines. They can be widely used in drilling steel, copper, aluminium, stainless

steel and plastic, in either plate or pipe form. The HSS annular cutters have gained huge popularity in the market. The entire range is available in various specifications that can be customised as per your requirements.

HSS material application													
Plastics GRP/CRP	Brass, Copper, Tin	Grey cast iron	Steel					Stainless steel		Aluminium		Exotic materials, Inconnell, Nimonic, HARDOX, Hastelloy	Rails
			< 500N	< 750N	< 900N	< 1,100N	< 1,400N	< 900N	≤ 900N	< 10% Si	≤ 10% Si		
●	○		●	●	○					○			

HSS profile

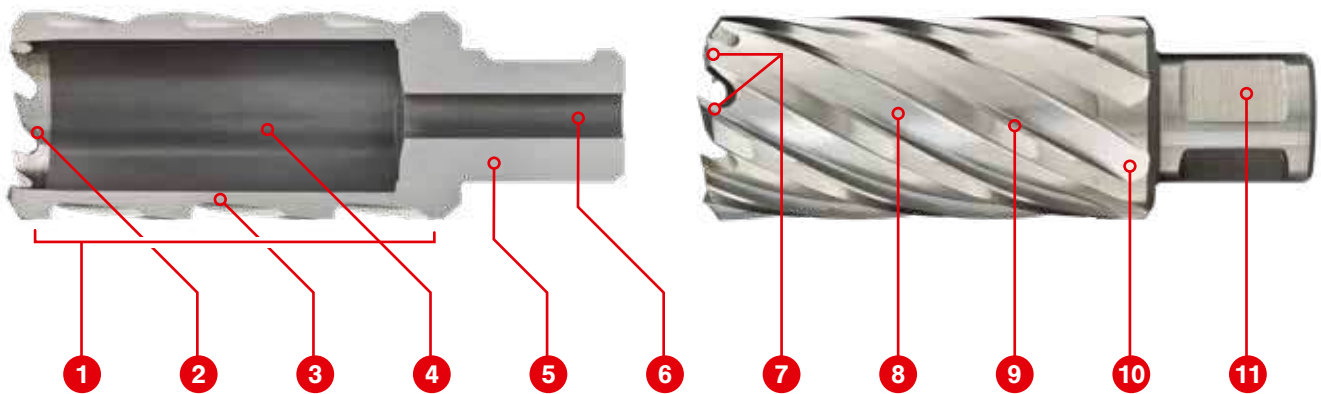

1. Stage hardening. Combines maximum hardness at the teeth with superior strength at the cutter body, reducing breakage to a minimum.
2. Inner ground cutting teeth. Helps stable "setting" of the cutter, reduces friction during drilling and helps slug ejection.
3. Wall thickness matched to the diameter of the cutter, combining the best possible cutting time with strength.
4. Tapered inside fitment prevents the cutter getting stuck. Guaranteed slug ejection with usage of the correct pilot pin.
5. Precise shank fitment for maximum interchangeability and close tolerance drilling without run-out.
6. Precise pilot pin fitment for perfect centration, hassle-free pin retraction and controlled lubricant flow.
7. Altering "continuous pre-cut" teeth geometry. Generates faster and more stable drilling performance and results in clear cuts of the highest precision and smooth, burr-free finishes.
8. Well-thought-out spiral flute angles for optimal chip removal.
9. Specially designed blades for optimum stability and heat-reduction.
10. Number of flutes and teeth matched to the diameter of the cutter for the best tooth load and superior cutting speeds.
11. Precision ground shanks for optimum fitment of the cutter itself in the tool holder and of pilot pin in the annular cutter. Increases safety, stability and accurate hole dimensions.

DoC 1" Weldon

Ø 7/16" - 4"

DIA Ø	Code
7/16"	HCS.7/16"
1/2"	HCS.1/2"
9/16"	HCS.9/16"
5/8"	HCS.5/8"
11/16"	HCS.11/16"
3/4"	HCS.3/4"
13/16"	HCS.13/16"
7/8"	HCS.7/8"
15/16"	HCS.15/16"
1"	HCS.1"
1 1/16"	HCS.1-1/16"
1 1/8"	HCS.1-1/8"
1 3/16"	HCS.1-3/16"
1 1/4"	HCS.1-1/4"
1 5/16"	HCS.1-5/16"

DIA Ø	Code
1 3/8"	HCS.1-3/8"
1 7/16"	HCS.1-7/16"
1 1/2"	HCS.1-1/2"
1 9/16"	HCS.1-9/16"
1 5/8"	HCS.1-5/8"
1 11/16"	HCS.1-11/16"
1 3/4"	HCS.1-3/4"
1 13/16"	HCS.1-13/16"
1 7/8"	HCS.1-7/8"
1 15/16"	HCS.1-15/16"
2"	HCS.2"
2 1/16"	HCS.2-1/16"
2 1/8"	HCS.2-1/8"
2 3/16"	HCS.2-3/16"
2 1/4"	HCS.2-1/4"

DIA Ø	Code
2 5/16"	HCS.2-5/16"
2 3/8"	HCS.2-3/8"
2 7/16"	HCS.2-7/16"
2 1/2"	HCS.2-1/2"
2 9/16"	HCS.2-9/16"
2 5/8"	HCS.2-5/8"
2 11/16"	HCS.2-11/16"
2 3/4"	HCS.2-3/4"
2 13/16"	HCS.2-13/16"
2 7/8"	HCS.2-7/8"
2 15/16"	HCS.2-15/16"
3"	HCS.3"
3 1/16"	HCS.3-1/16"
3 1/8"	HCS.3-1/8"
3 3/16"	HCS.3-3/16"

DIA Ø	Code
3 1/4"	HCS.3-1/4"
3 5/16"	HCS.3-5/16"
3 3/8"	HCS.3-3/8"
3 7/16"	HCS.3-7/16"
3 1/2"	HCS.3-1/2"
3 9/16"	HCS.3-9/16"
3 5/8"	HCS.3-5/8"
3 11/16"	HCS.3-11/16"
3 3/4"	HCS.3-3/4"
3 13/16"	HCS.3-13/16"
3 7/8"	HCS.3-7/8"
3 15/16"	HCS.3-15/16"
4"	HCS.4"

HSS

Weldon shank



WeldNit shank



DoC 1" WeldNit

Ø 7/16" - 2 1/4"

DIA Ø	Code
7/16"	HCSU.7/16"
1/2"	HCSU.1/2"
9/16"	HCSU.9/16"
5/8"	HCSU.5/8"
11/16"	HCSU.11/16"
3/4"	HCSU.3/4"
13/16"	HCSU.13/16"
7/8"	HCSU.7/8"

DIA Ø	Code
15/16"	HCSU.15/16"
1"	HCSU.1"
1 1/16"	HCSU.1-1/16"
1 1/8"	HCSU.1-1/8"
1 3/16"	HCSU.1-3/16"
1 1/4"	HCSU.1-1/4"
1 5/16"	HCSU.1-5/16"
1 3/8"	HCSU.1-3/8"

DIA Ø	Code
1 7/16"	HCSU.1-7/16"
1 1/2"	HCSU.1-1/2"
1 9/16"	HCSU.1-9/16"
1 5/8"	HCSU.1-5/8"
1 11/16"	HCSU.1-11/16"
1 3/4"	HCSU.1-3/4"
1 13/16"	HCSU.1-13/16"
1 7/8"	HCSU.1-7/8"

DIA Ø	Code
1 15/16"	HCSU.1-15/16"
2"	HCSU.2"
2 1/16"	HCSU.2-1/16"
2 1/8"	HCSU.2-1/8"
2 3/16"	HCSU.2-3/16"
2 1/4"	HCSU.2-1/4"

Shank sizes

DIA Ø 12 - 60 mm:
19.05 mm (3/4")

DIA Ø 61 - 100 mm:
31.75 mm (1 1/4")



DoC

Depth of Cut measured inside outer

DoC 30 mm Weldon

Ø 12 - 25 mm

DIA Ø	Code
12	HCS.120
13	HCS.130
14	HCS.140
15	HCS.150

DIA Ø	Code
16	HCS.160
17	HCS.170
18	HCS.180
19	HCS.190

DIA Ø	Code
20	HCS.200
21	HCS.210
22	HCS.220
23	HCS.230

DIA Ø	Code
24	HCS.240
25	HCS.250

HSS

DoC 2" Weldon Ø 7/16" - 4"

Weldon shank



WeiNit shank



DIA Ø	Code
7/16"	HCL.7/16"
31/64"	HCL.31/64"
33/64"	HCL.33/64"
1/2"	HCL.1/2"
17/32"	HCL.17/32"
9/16"	HCL.9/16"
37/64"	HCL.37/64"
5/8"	HCL.5/8"
21/32"	HCL.21/32"
11/16"	HCL.11/16"
3/4"	HCL.3/4"
49/64"	HCL.49/64"
13/16"	HCL.13/16"
7/8"	HCL.7/8"
59/64"	HCL.59/64"
15/16"	HCL.15/16"
1"	HCL.1"

DIA Ø	Code
1 1/16"	HCL.1-1/16"
1 7/64"	HCL.1-7/64"
1 1/8"	HCL.1-1/8"
1 11/64"	HCL.1-11/64"
1 3/16"	HCL.1-3/16"
1 1/4"	HCL.1-1/4"
1 5/16"	HCL.1-5/16"
1 3/8"	HCL.1-3/8"
1 7/16"	HCL.1-7/16"
1 1/2"	HCL.1-1/2"
1 9/16"	HCL.1-9/16"
1 5/8"	HCL.1-5/8"
1 11/16"	HCL.1-11/16"
1 3/4"	HCL.1-3/4"
1 13/16"	HCL.1-13/16"
1 7/8"	HCL.1-7/8"
1 15/16"	HCL.1-15/16"

DIA Ø	Code
2"	HCL.2"
2 1/16"	HCL.2-1/16"
2 1/8"	HCL.2-1/8"
2 3/16"	HCL.2-3/16"
2 1/4"	HCL.2-1/4"
2 5/16"	HCL.2-5/16"
2 3/8"	HCL.2-3/8"
2 7/16"	HCL.2-7/16"
2 1/2"	HCL.2-1/2"
2 9/16"	HCL.2-9/16"
2 5/8"	HCL.2-5/8"
2 11/16"	HCL.2-11/16"
2 3/4"	HCL.2-3/4"
2 13/16"	HCL.2-13/16"
2 7/8"	HCL.2-7/8"
2 15/16"	HCL.2-15/16"
3"	HCL.3"

DIA Ø	Code
3 1/16"	HCL.3-1/16"
3 1/8"	HCL.3-1/8"
3 3/16"	HCL.3-3/16"
3 1/4"	HCL.3-1/4"
3 5/16"	HCL.3-5/16"
3 3/8"	HCL.3-3/8"
3 7/16"	HCL.3-7/16"
3 1/2"	HCL.3-1/2"
3 9/16"	HCL.3-9/16"
3 5/8"	HCL.3-5/8"
3 11/16"	HCL.3-11/16"
3 3/4"	HCL.3-3/4"
3 13/16"	HCL.3-13/16"
3 7/8"	HCL.3-7/8"
3 15/16"	HCL.3-15/16"
4"	HCL.4"

Shank sizes

DIA Ø 12 - 60 mm:
19.05 mm (3/4")

DIA Ø 61 - 100 mm:
31.75 mm (1 1/4")



DoC
Depth of Cut measured inside cutter

DoC 2" WeiNit Ø 7/16" - 2 1/4"

DIA Ø	Code
7/16"	HCLU.7/16"
1/2"	HCLU.1/2"
9/16"	HCLU.9/16"
5/8"	HCLU.5/8"
11/16"	HCLU.11/16"
3/4"	HCLU.3/4"
13/16"	HCLU.13/16"
7/8"	HCLU.7/8"

DIA Ø	Code
15/16"	HCLU.15/16"
1"	HCLU.1"
1 1/16"	HCLU.1-1/16"
1 1/8"	HCLU.1-1/8"
1 3/16"	HCLU.1-3/16"
1 1/4"	HCLU.1-1/4"
1 5/16"	HCLU.1-5/16"
1 3/8"	HCLU.1-3/8"

DIA Ø	Code
1 7/16"	HCLU.1-7/16"
1 1/2"	HCLU.1-1/2"
1 9/16"	HCLU.1-9/16"
1 5/8"	HCLU.1-5/8"
1 11/16"	HCLU.1-11/16"
1 3/4"	HCLU.1-3/4"
1 13/16"	HCLU.1-13/16"
1 7/8"	HCLU.1-7/8"

DIA Ø	Code
1 15/16"	HCLU.1-15/16"
2"	HCLU.2"
2 1/16"	HCLU.2-1/16"
2 1/8"	HCLU.2-1/8"
2 3/16"	HCLU.2-3/16"
2 1/4"	HCLU.2-1/4"

DoC 55 mm Weldon Ø 12 - 67 mm

DIA Ø	Code
12	HCL.120
13	HCL.130
13,5	HCL.135
14	HCL.140
14,5	HCL.145
15	HCL.150
15,5	HCL.155
16	HCL.160
16,5	HCL.165
17	HCL.170
17,5	HCL.175
18	HCL.180
19	HCL.190
19,5	HCL.195

DIA Ø	Code
20	HCL.200
21	HCL.210
21,5	HCL.215
22	HCL.220
23,5	HCL.235
24	HCL.240
25	HCL.250
26	HCL.260
26,5	HCL.265
27	HCL.270
28	HCL.280
29	HCL.290
30	HCL.300

DIA Ø	Code
31	HCL.310
32	HCL.320
33	HCL.330
34	HCL.340
35	HCL.350
36	HCL.360
37	HCL.370
38	HCL.380
39	HCL.390
40	HCL.400
41	HCL.410
42	HCL.420
43	HCL.430
44	HCL.440

DIA Ø	Code
45	HCL.450
46	HCL.460
47	HCL.470
48	HCL.480
49	HCL.490
50	HCL.500
51	HCL.510
52	HCL.520
60	HCL.600
60,5	HCL.605
67	HCL.670

Set HSS imperial

6 piece cutter sets



DoC 1"

- 6 piece annular cutter set
- Cutter sizes \varnothing 9/16", 11/16", 13/16"
- (2 of each DoC)
- Pilot pin IBC.70 included

HCS.KIT/8



DoC 1" & 2"

- 6 piece annular cutter set
- Cutter sizes \varnothing 9/16", 11/16", 13/16"
- (1 of each DoC)
- Pilot pins IBC.70 & IBC.90 included

HCS.KIT/9

10 piece cutter sets



DoC 1"

- 10 piece annular cutter set
- Cutter sizes 2 x \varnothing 9/16", 2 x \varnothing 11/16", 2 x \varnothing 13/16", 2 x \varnothing 7/8", \varnothing 15/16", \varnothing 1"
- 2 x Pilot pin IBC.70 included

HSS.KIT/10S-11

DoC 1"

- 10 piece annular cutter set
- Cutter sizes 3 x \varnothing 9/16", 3 x \varnothing 13/16", 3 x \varnothing 7/8", \varnothing 15/16"
- 2 x Pilot pin IBC.70 included

HSS.KIT/10S-12



DoC 2"

- 10 piece annular cutter set
- Cutter sizes 2 x \varnothing 9/16", 2 x \varnothing 11/16", 2 x \varnothing 13/16", 2 x \varnothing 7/8", \varnothing 15/16", \varnothing 1"
- 2 x Pilot pin IBC.90 included

HSS.KIT/10L-11

DoC 2"

- 10 piece annular cutter set
- Cutter sizes 3 x \varnothing 9/16", 3 x \varnothing 13/16", 3 x \varnothing 7/8", \varnothing 15/16"
- 2 x Pilot pin IBC.90 included

HSS.KIT/10L-12

Annular cutter

High Speed Steel Stack



Standard HSS Euroboor annular cutters feature teeth geometry which is optimised for use on single layer workpieces, ensuring the fastest and best drilling performance. The rest material created with the use of these cutters is our signature: the Euroboor slug. The rim on this slug is exactly what prevents our standard HSS cutters from penetrating the second layer of material. In order to drill multiple layers of material simultaneously, we recommend the use of our annular cutters with stack geometry.

The unique teeth profile ensures safe and stable penetration: layer for layer.

Combined with the standard performance improving characteristics of Euroboor annular cutters this results in smooth layer transitions, precise and clean hole finishes and the time savings you are looking for.

HSS stack material application													
Plastics GRP/CRP	Brass, Copper, Tin	Grey cast iron	Steel					Stainless steel		Aluminium		Exotic materials, Inconnell, Nimonic, HARDOX, Hastelloy	Rails
			< 500N	< 750N	< 900N	< 1,100N	< 1,400N	< 900N	≤ 900N	< 10% Si	≤ 10% Si		
●	○		●	●	○					○			

HSS profile

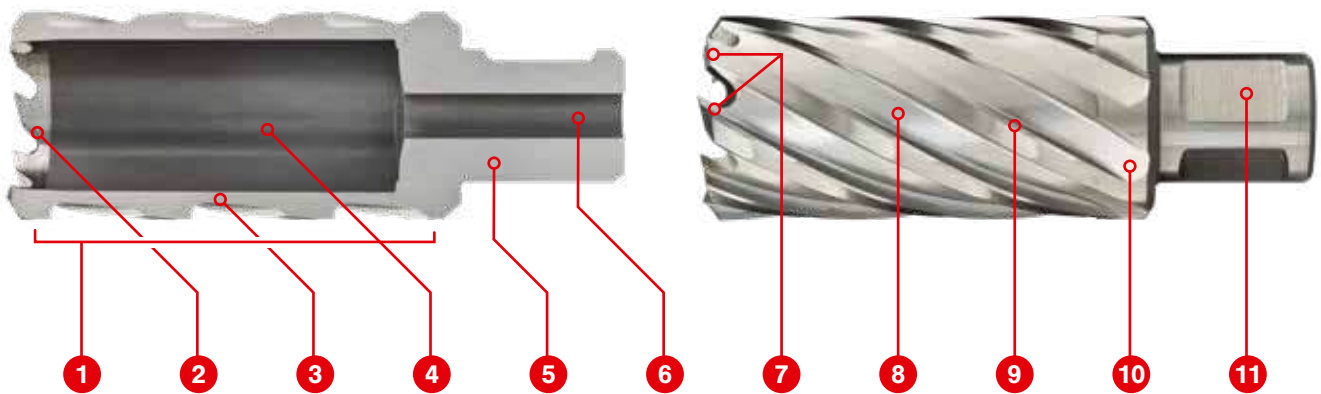

1. Stage hardening. Combines maximum hardness at the teeth with superior strength at the cutter body, reducing breakage to a minimum.
2. Extra deep inner ground cutting teeth. Helps stable "setting" of the cutter, reduces friction during drilling and helps (multiple) slug ejection.
3. Wall thickness matched to the diameter of the cutter, combining the best possible cutting time with strength.
4. Tapered inside fitment prevents the cutter getting stuck. Guaranteed slug(s) ejection with usage of the correct pilot pin.
5. Precise shank fitment for maximum interchangeability and close tolerance drilling without run-out.
6. Precise pilot pin fitment for perfect centration, hassle-free pin retraction and controlled lubricant flow.
7. Stack teeth geometry ensures stable and precise material penetration with fast cutting performance
8. Well-thought-out spiral flute angles for optimal chip removal.
9. Specially designed blades for optimum stability and heat-reduction.
10. Number of flutes and teeth matched to the diameter of the cutter for the best tooth load and superior cutting speeds.
11. Precision ground shanks for optimum fitment of the cutter itself in the tool holder and of pilot pin in the annular cutter. Increases safety, stability and accurate hole dimensions.

DoC 2" Weldon

Ø 3/4" - 1 1/4"

DIA Ø	Code	DIA Ø	Code
3/4"	HCPL.3/4"	1 1/16"	HCPL.1-1/16"
13/16"	HCPL.13/16"	1 1/8"	HCPL.1-1/8"
7/8"	HCPL.7/8"	1 3/16"	HCPL.1-3/16"
15/16"	HCPL.15/16"	1 1/4"	HCPL.1-1/4"
1"	HCPL.1"		

DoC 3" Weldon

Ø 3/4" - 1 1/4"

DIA Ø	Code	DIA Ø	Code
3/4"	HCPY.3/4"	1 1/16"	HCPY.1-1/16"
13/16"	HCPY.13/16"	1 1/8"	HCPY.1-1/8"
7/8"	HCPY.7/8"	1 3/16"	HCPY.1-3/16"
15/16"	HCPY.15/16"	1 1/4"	HCPY.1-1/4"
1"	HCPY.1"		

HSS Stack

Weldon shank



Shank sizes

DIA Ø 18 - 32 mm;
19.05 mm (3/4")

DIA Ø 11/16" - 1 1/4";
3/4"

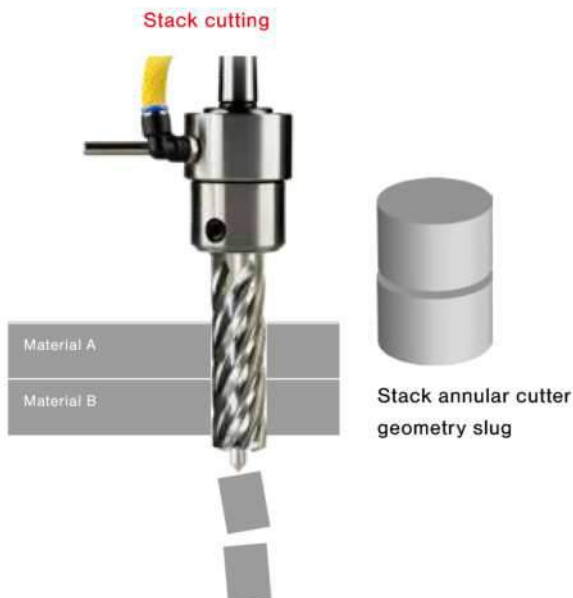

Annular cutter

High Speed Steel Cobalt



Euroboor HSS-Cobalt annular cutters are made of Molybdenum-Chromium-Vanadium-Tungsten alloy High Speed Steel with an additional 8% Cobalt (M42). The HSS-Cobalt annular cutter is specifically designed to remain cool when cutting holes. All flutes are fully ground, resulting in super-fast feed rates and smooth holes

in hard materials, providing better chip clearance and higher cutting performances. The M42 HSS-Cobalt annular cutter is widely used in the metalworking industry for its superior red hardness compared to more conventional high speed steels. This will lead to shorter cycle times in production environments due to higher cutting speeds.

HSS-Cobalt material application

● Optimal ○ Good ○ Possible

Plastics GRP/CRP	Brass, Copper, Tin	Grey cast iron	Steel					Stainless steel		Aluminium		Exotic materials, Inconnell, Nimonic, HARDOX, Hastelloy	Rails
			< 500N	< 750N	< 900N	< 1,100N	< 1,400N	< 900N	≤ 900N	< 10% Si	≤ 10% Si		
●	●	○	●	●	●	○	○	○	○	●	○	○	

HSS-Cobalt profile

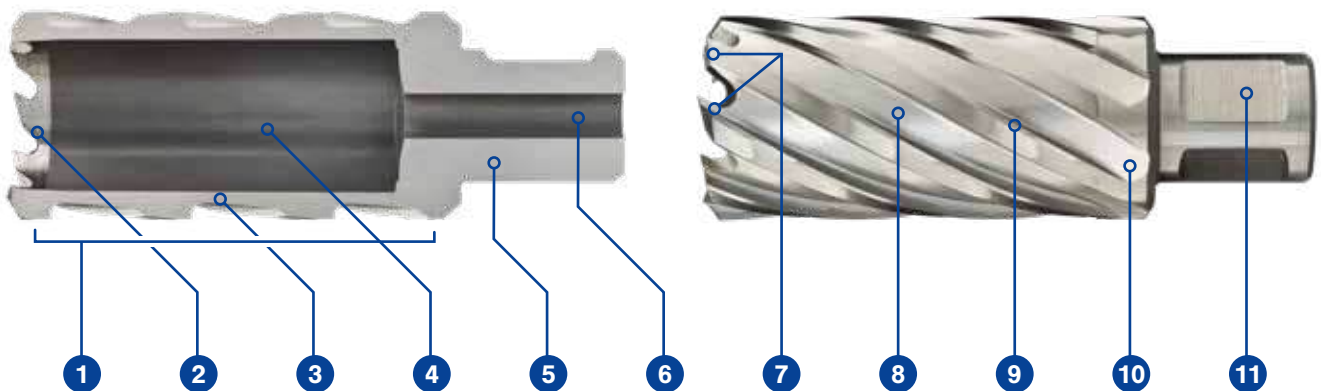

1. Stage hardening. Combines maximum hardness at the teeth with superior strength at the cutter body, reducing breakage to a minimum.
2. Inner ground cutting teeth. Helps stable "setting" of the cutter, reduces friction during and drilling and helps slug ejection.
3. Wall thickness matched to the diameter of the cutter, combining the best possible cutting time with strength.
4. Tapered inside fitment prevents the cutter getting stuck. Guaranteed slug ejection with usage of the correct pilot pin.
5. Precise shank fitment for maximum interchangeability and close tolerance drilling without run-out.
6. Precise pilot pin fitment for perfect centration, hassle-free pin retraction and controlled lubricant flow.
7. Altering "continuous pre-cut" teeth geometry. Generates faster and more stable drilling performance and results in clear cuts of the highest precision and smooth, burr-free finishes.
8. Well-thought-out spiral flute angles for optimal chip removal.
9. Specially designed blades for optimum stability and heat-reduction.
10. Number of flutes and teeth matched to the diameter of the cutter for the best tooth load and superior cutting speeds.
11. Precision ground shanks for optimum fitment of the cutter itself in the tool holder and of pilot pin in the annular cutter. Increases safety, stability and accurate hole dimensions.

DoC 1" Weldon

Ø 7/16" - 3"

DIA Ø	Code
7/16"	IBS.7/16"
1/2"	IBS.1/2"
9/16"	IBS.9/16"
5/8"	IBS.5/8"
11/16"	IBS.11/16"
3/4"	IBS.3/4"
13/16"	IBS.13/16"
7/8"	IBS.7/8"
15/16"	IBS.15/16"

DIA Ø	Code
1"	IBS.1"
1 1/16"	IBS.1-1/16"
1 1/8"	IBS.1-1/8"
1 3/16"	IBS.1-3/16"
1 1/4"	IBS.1-1/4"
1 5/16"	IBS.1-5/16"
1 3/8"	IBS.1-3/8"
1 7/16"	IBS.1-7/16"
1 1/2"	IBS.1-1/2"

DIA Ø	Code
1 9/16"	IBS.1-9/16"
1 5/8"	IBS.1-5/8"
1 11/16"	IBS.1-11/16"
1 3/4"	IBS.1-3/4"
1 13/16"	IBS.1-13/16"
1 7/8"	IBS.1-7/8"
1 15/16"	IBS.1-15/16"
2"	IBS.2"
2 1/16"	IBS.2 1/16"

DIA Ø	Code
2 1/8"	IBS.2 1/8"
2 1/4"	IBS.2 1/4"
2 3/8"	IBS.2 3/8"
2 7/16"	IBS.2 7/16"
2 1/2"	IBS.2 1/2"
2 9/16"	IBS.2 9/16"
2 5/8"	IBS.2 5/8"
2 3/4"	IBS.2 3/4"
3"	IBS.3"

**HSS
Cobalt**

Weldon shank



Shank sizes

DIA Ø 12 - 60 mm;
19.05 mm (3/4")

DIA Ø 7/16" - 2 5/16";
3/4"



DoC 2" Weldon

Ø 7/16" - 2 7/8"

DIA Ø	Code
7/16"	IBL.7/16"
1/2"	IBL.1/2"
9/16"	IBL.9/16"
5/8"	IBL.5/8"
11/16"	IBL.11/16"
3/4"	IBL.3/4"
13/16"	IBL.13/16"
7/8"	IBL.7/8"
15/16"	IBL.15/16"
1"	IBL.1"

DIA Ø	Code
1 1/16"	IBL.1-1/16"
1 1/8"	IBL.1-1/8"
1 3/16"	IBL.1-3/16"
1 1/4"	IBL.1-1/4"
1 5/16"	IBL.1-5/16"
1 3/8"	IBL.1-3/8"
1 7/16"	IBL.1-7/16"
1 1/2"	IBL.1-1/2"
1 9/16"	IBL.1-9/16"

DIA Ø	Code
1 5/8"	IBL.1-5/8"
1 11/16"	IBL.1-11/16"
1 3/4"	IBL.1-3/4"
1 13/16"	IBL.1-13/16"
1 7/8"	IBL.1-7/8"
1 15/16"	IBL.1-15/16"
2"	IBL.2"
2 1/16"	IBL.2-1/16"
2 1/8"	IBL.2-1/8"

DIA Ø	Code
2 3/16"	IBL.2-3/16"
2 1/4"	IBL.2-1/4"
2 5/16"	IBL.2-5/16"
2 3/8"	IBL.2-3/8"
2 1/2"	IBL.2-1/2"
2 9/16"	IBL.2-9/16"
2 5/8"	IBL.2-5/8"
2 3/4"	IBL.2-3/4"
2 7/8"	IBL.2-7/8"

DoC 3" Weldon

Ø 7/16" - 2 7/8"

DIA Ø	Code
3/4"	IBY.3/4"
13/16"	IBY.13/16"
7/8"	IBY.7/8"
15/16"	IBY.15/16"

DIA Ø	Code
1"	IBY.1"
1 1/16"	IBY.1-1/16"
1 1/8"	IBY.1-1/8"
1 3/16"	IBY.1-3/16"

DIA Ø	Code
1 1/4"	IBY.1-1/4"
1 5/16"	IBY.1-5/16"
1 3/8"	IBY.1-3/8"
1 1/2"	IBY.1-1/2"

DIA Ø	Code
1 9/16"	IBY.1-9/16"
1 3/4"	IBY.1-3/4"
1 7/8"	IBY.1-7/8"

Annular cutter

Tungsten Carbide Tipped

Euroboor TCT (**SANDVIK**) annular cutters are equipped with a spiral flute which creates optimum chip removal and makes seizure virtually impossible. These annular cutters are used for example in hardened materials such as HARDOX steel, stainless steels and high

tensile strength steel such as railway tracks. Because of the above composition, and when used in a proper way, these cutters are less susceptible to breakage than standard High Speed Steel cutters, especially in larger diameters and lengths.

TCT material application													
Plastics GRP/CRP	Brass, Copper, Tin	Grey cast iron	Steel					Stainless steel		Aluminium		Exotic materials, Inconnell, Nimonic, HARDOX, Hastelloy	Rails
			< 500N	< 750N	< 900N	< 1,100N	< 1,400N	< 900N	≤ 900N	< 10% Si	≤ 10% Si		
	○	●	●	●	●	●	●	●	●	●	●	●	○

TCT profile

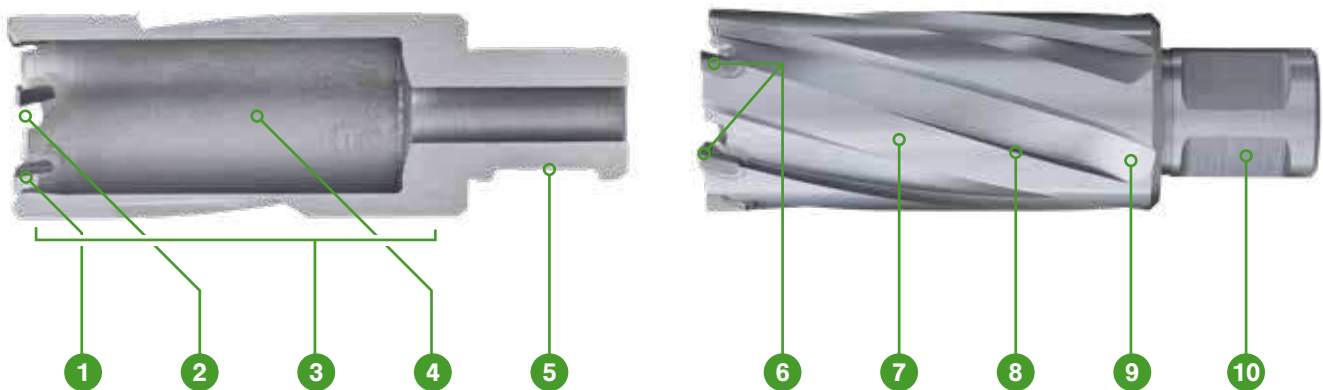

- Extremely hard and durable tungsten carbide cutting teeth (**SANDVIK**) for the hardest of drilling tasks. Offset positioning for the lowest possible heat development.
- Optimised cutting angles for shortest drilling times and clearest cuts.
- Special alloy body for optimum strength and durability.
- Tapered inside fitment prevents the cutter getting stuck. Guaranteed slug ejection with usage of the correct pilot pin.
- Precise shank fitment for maximum interchangeability and close tolerance drilling without run-out.
- Altering "continuous pre-cut" teeth geometry. Generates faster and more stable drilling performance and results in clear cuts of the highest precision and smooth, burr-free finishes. **SANDVIK** carbide tipped.
- Well-thought-out spiral flute angles for optimal chip removal.
- Specially designed blades for optimum stability and heat-reduction.
- Number of flutes and teeth matched to the diameter of the cutter for the best tooth load and superior cutting speeds.
- Precision ground shanks for optimum fitment of the cutter itself in the tool holder and of pilot pin in the annular cutter. Increases safety, stability and accurate hole dimensions.

DoC 1" Weldon

Ø 7/16" - 3"

DIA Ø	Code
7/16"	HMS.7/16"
1/2"	HMS.1/2"
9/16"	HMS.9/16"
5/8"	HMS.5/8"
11/16"	HMS.11/16"
3/4"	HMS.3/4"
13/16"	HMS.13/16"
7/8"	HMS.7/8"
15/16"	HMS.15/16"
1"	HMS.1"
1 1/16"	HMS.1-1/16"

DIA Ø	Code
1 1/8"	HMS.1-1/8"
1 3/16"	HMS.1-3/16"
1 1/4"	HMS.1-1/4"
1 5/16"	HMS.1-5/16"
1 3/8"	HMS.1-3/8"
1 7/16"	HMS.1-7/16"
1 1/2"	HMS.1-1/2"
1 9/16"	HMS.1-9/16"
1 5/8"	HMS.1-5/8"
1 11/16"	HMS.1-11/16"
1 3/4"	HMS.1-3/4"

DIA Ø	Code
1 13/16"	HMS.1-13/16"
1 7/8"	HMS.1-7/8"
1 15/16"	HMS.1-15/16"
2"	HMS.2"
2 1/16"	HMS.2-1/16"
2 1/8"	HMS.2-1/8"
2 3/16"	HMS.2-3/16"
2 1/4"	HMS.2-1/4"
2 5/16"	HMS.2-5/16"
2 3/8"	HMS.2-3/8"
2 7/16"	HMS.2-7/16"

DIA Ø	Code
2 1/2"	HMS.2-1/2"
2 9/16"	HMS.2-9/16"
2 5/8"	HMS.2-5/8"
2 11/16"	HMS.2-11/16"
2 3/4"	HMS.2-3/4"
2 13/16"	HMS.2-13/16"
2 7/8"	HMS.2-7/8"
2 15/16"	HMS.2-15/16"
3"	HMS.3"

TCT

Weldon shank



WeiNit shank



DoC 1" WeiNit

Ø 7/16" - 2 5/16"

DIA Ø	Code
7/16"	HMSU.7/16"
1/2"	HMSU.1/2"
9/16"	HMSU.9/16"
5/8"	HMSU.5/8"
11/16"	HMSU.11/16"
3/4"	HMSU.3/4"
13/16"	HMSU.13/16"
7/8"	HMSU.7/8"

DIA Ø	Code
15/16"	HMSU.15/16"
1"	HMSU.1"
1 1/16"	HMSU.1-1/16"
1 1/8"	HMSU.1-1/8"
1 3/16"	HMSU.1-3/16"
1 1/4"	HMSU.1-1/4"
1 5/16"	HMSU.1-5/16"
1 3/8"	HMSU.1-3/8"

DIA Ø	Code
1 7/16"	HMSU.1-7/16"
1 1/2"	HMSU.1-1/2"
1 9/16"	HMSU.1-9/16"
1 5/8"	HMSU.1-5/8"
1 11/16"	HMSU.1-11/16"
1 3/4"	HMSU.1-3/4"
1 13/16"	HMSU.1-13/16"
1 7/8"	HMSU.1-7/8"

DIA Ø	Code
1 15/16"	HMSU.1-15/16"
2"	HMSU.2"
2 1/16"	HMSU.2-1/16"
2 1/8"	HMSU.2-1/8"
2 3/16"	HMSU.2-3/16"
2 1/4"	HMSU.2-1/4"
2 5/16"	HMSU.2-5/16"

Shank sizes

DIA Ø 12 - 60 mm:
19.05 mm (3/4")

DIA Ø 61 - 200 mm:
31.75 mm (1 1/4")



DoC
Depth of Cut
measured
inside
cutter

DoC 35 mm Weldon

Ø 12 - 20 mm

DIA Ø	Code
12	HMS.120

DIA Ø	Code
14	HMS.140

DIA Ø	Code
16	HMS.160

DIA Ø	Code
20	HMS.200

TCT

DoC 2" Weldon Ø 7/16" - 8"

Weldon shank



WeiNit shank



Shank sizes

DIA Ø 12 - 60 mm:
19.05 mm (3/4")

DIA Ø 61 - 200 mm:
31.75 mm (1 1/4")



DoC

Depth of Cut measured inside cutter

DIA Ø	Code
7/16"	HML.7/16"
1/2"	HML.1/2"
9/16"	HML.9/16"
5/8"	HML.5/8"
11/16"	HML.11/16"
3/4"	HML.3/4"
13/16"	HML.13/16"
7/8"	HML.7/8"
15/16"	HML.15/16"
1"	HML.1"
1 1/16"	HML.1-1/16"
1 1/8"	HML.1-1/8"
1 3/16"	HML.1-3/16"
1 1/4"	HML.1-1/4"
1 5/16"	HML.1-5/16"
1 3/8"	HML.1-3/8"
1 7/16"	HML.1-7/16"
1 1/2"	HML.1-1/2"
1 9/16"	HML.1-9/16"
1 5/8"	HML.1-5/8"
1 11/16"	HML.1-11/16"
1 3/4"	HML.1-3/4"
1 13/16"	HML.1-13/16"
1 7/8"	HML.1-7/8"
1 15/16"	HML.1-15/16"
2"	HML.2"
2 1/16"	HML.2-1/16"
2 1/8"	HML.2-1/8"
2 3/16"	HML.2-3/16"
2 1/4"	HML.2-1/4"
2 5/16"	HML.2-5/16"

DIA Ø	Code
2 3/8"	HML.2-3/8"
2 7/16"	HML.2-7/16"
2 1/2"	HML.2-1/2"
2 9/16"	HML.2-9/16"
2 5/8"	HML.2-5/8"
2 11/16"	HML.2-11/16"
2 3/4"	HML.2-3/4"
2 13/16"	HML.2-13/16"
2 7/8"	HML.2-7/8"
2 15/16"	HML.2-15/16"
3"	HML.3"
3 1/16"	HML.3-1/16"
3 1/8"	HML.3-1/8"
3 3/16"	HML.3-3/16"
3 1/4"	HML.3-1/4"
3 5/16"	HML.3-5/16"
3 3/8"	HML.3-3/8"
3 7/16"	HML.3-7/16"
3 1/2"	HML.3-1/2"
3 9/16"	HML.3-9/16"
3 5/8"	HML.3-5/8"
3 11/16"	HML.3-11/16"
3 3/4"	HML.3-3/4"
3 13/16"	HML.3-13/16"
3 7/8"	HML.3-7/8"
3 15/16"	HML.3-15/16"
4"	HML.4"
4 1/16"	HML.4-1/16"
4 1/8"	HML.4-1/8"
4 3/16"	HML.4-3/16"
4 1/4"	HML.4-1/4"

DIA Ø	Code
4 5/16"	HML.4-5/16"
4 3/8"	HML.4-3/8"
4 7/16"	HML.4-7/16"
4 1/2"	HML.4-1/2"
4 9/16"	HML.4-9/16"
4 5/8"	HML.4-5/8"
4 11/16"	HML.4-11/16"
4 3/4"	HML.4-3/4"
4 13/16"	HML.4-13/16"
4 7/8"	HML.4-7/8"
4 15/16"	HML.4-15/16"
5"	HML.5"
5 1/16"	HML.5-1/16"
5 1/8"	HML.5-1/8"
5 3/16"	HML.5-3/16"
5 1/4"	HML.5-1/4"
5 5/16"	HML.5-5/16"
5 3/8"	HML.5-3/8"
5 7/16"	HML.5-7/16"
5 1/2"	HML.5-1/2"
5 9/16"	HML.5-9/16"
5 5/8"	HML.5-5/8"
5 11/16"	HML.5-11/16"
5 3/4"	HML.5-3/4"
5 13/16"	HML.5-13/16"
5 7/8"	HML.5-7/8"
5 15/16"	HML.5-15/16"
6"	HML.6"
6 1/16"	HML.6-1/16"
6 1/8"	HML.6-1/8"
6 3/16"	HML.6-3/16"

DIA Ø	Code
6 1/4"	HML.6-1/4"
6 5/16"	HML.6-5/16"
6 3/8"	HML.6-3/8"
6 7/16"	HML.6-7/16"
6 1/2"	HML.6-1/2"
6 9/16"	HML.6-9/16"
6 5/8"	HML.6-5/8"
6 11/16"	HML.6-11/16"
6 3/4"	HML.6-3/4"
6 13/16"	HML.6-13/16"
6 7/8"	HML.6-7/8"
6 15/16"	HML.6-15/16"
7"	HML.7"
7 1/16"	HML.7-1/16"
7 1/8"	HML.7-1/8"
7 3/16"	HML.7-3/16"
7 1/4"	HML.7-1/4"
7 5/16"	HML.7-5/16"
7 3/8"	HML.7-3/8"
7 7/16"	HML.7-7/16"
7 1/2"	HML.7-1/2"
7 9/16"	HML.7-9/16"
7 5/8"	HML.7-5/8"
7 11/16"	HML.7-11/16"
7 3/4"	HML.7-3/4"
7 13/16"	HML.7-13/16"
7 7/8"	HML.7-7/8"
7 15/16"	HML.7-15/16"
8"	HML.8"

DoC 2" WeiNit Ø 7/16" - 2 5/16"

DIA Ø	Code
7/16"	HMLU.7/16"
1/2"	HMLU.1/2"
9/16"	HMLU.9/16"
5/8"	HMLU.5/8"
11/16"	HMLU.11/16"
3/4"	HMLU.3/4"
13/16"	HMLU.13/16"
7/8"	HMLU.7/8"

DIA Ø	Code
15/16"	HMLU.15/16"
1"	HMLU.1"
1 1/16"	HMLU.1-1/16"
1 1/8"	HMLU.1-1/8"
1 3/16"	HMLU.1-3/16"
1 1/4"	HMLU.1-1/4"
1 5/16"	HMLU.1-5/16"
1 3/8"	HMLU.1-3/8"

DIA Ø	Code
1 7/16"	HMLU.1-7/16"
1 1/2"	HMLU.1-1/2"
1 9/16"	HMLU.1-9/16"
1 5/8"	HMLU.1-5/8"
1 11/16"	HMLU.1-11/16"
1 3/4"	HMLU.1-3/4"
1 13/16"	HMLU.1-13/16"
1 7/8"	HMLU.1-7/8"

DIA Ø	Code
1 15/16"	HMLU.1-15/16"
2"	HMLU.2"
2 1/16"	HMLU.2-1/16"
2 1/8"	HMLU.2-1/8"
2 3/16"	HMLU.2-3/16"
2 1/4"	HMLU.2-1/4"
2 5/16"	HMLU.2-5/16"

DoC 55 mm Weldon

Ø 12 - 200 mm

DIA Ø	Code
12	HML.120
13	HML.130
14	HML.140
15	HML.150
16	HML.160
17	HML.170
18	HML.180
19	HML.190
20	HML.200
21	HML.210
22	HML.220
23	HML.230
24	HML.240

DIA Ø	Code
25	HML.250
26	HML.260
27	HML.270
28	HML.280
29	HML.290
30	HML.300
31	HML.310
32	HML.320
33	HML.330
34	HML.340
35	HML.350
36	HML.360
37	HML.370

DIA Ø	Code
38	HML.380
39	HML.390
40	HML.400
41	HML.410
42	HML.420
43	HML.430
44	HML.440
45	HML.450
46	HML.460
47	HML.470
48	HML.480
49	HML.490
50	HML.500

DIA Ø	Code
51	HML.510
52	HML.520
77	HML.770
91	HML.910
100	HML.1000
103	HML.1030
130	HML.1300
160	HML.1600
180	HML.1800
200	HML.2000

TCT

Weldon shank



WeiNit shank



DoC 55 mm WeiNit

Ø 18 - 39 mm

DIA Ø	Code
18	HMLU.180
19	HMLU.190

DIA Ø	Code
26	HMLU.260
27	HMLU.270

DIA Ø	Code
29	HMLU.290
33	HMLU.330

DIA Ø	Code
37	HMLU.370
39	HMLU.390

Shank sizes

DIA Ø 12 - 60 mm:
19.05 mm (3/4")

DIA Ø 61 - 200 mm:
31.75 mm (1 1/4")

DoC 3" Weldon

Ø 7/16" - 3"

DIA Ø	Code
7/16"	HMY.7/16"
1/2"	HMY.1/2"
9/16"	HMY.9/16"
5/8"	HMY.5/8"
11/16"	HMY.11/16"
3/4"	HMY.3/4"
13/16"	HMY.13/16"
7/8"	HMY.7/8"
15/16"	HMY.15/16"
1"	HMY.1"
1 1/16"	HMY.1-1/16"

DIA Ø	Code
1 1/8"	HMY.1-1/8"
1 3/16"	HMY.1-3/16"
1 1/4"	HMY.1-1/4"
1 5/16"	HMY.1-5/16"
1 3/8"	HMY.1-3/8"
1 7/16"	HMY.1-7/16"
1 1/2"	HMY.1-1/2"
1 9/16"	HMY.1-9/16"
1 5/8"	HMY.1-5/8"
1 11/16"	HMY.1-11/16"
1 3/4"	HMY.1-3/4"

DIA Ø	Code
1 13/16"	HMY.1-13/16"
1 7/8"	HMY.1-7/8"
1 15/16"	HMY.1-15/16"
2"	HMY.2"
2 1/16"	HMY.2-1/16"
2 1/8"	HMY.2-1/8"
2 3/16"	HMY.2-3/16"
2 1/4"	HMY.2-1/4"
2 5/16"	HMY.2-5/16"
2 3/8"	HMY.2-3/8"
2 7/16"	HMY.2-7/16"

DIA Ø	Code
2 1/2"	HMY.2-1/2"
2 9/16"	HMY.2-9/16"
2 5/8"	HMY.2-5/8"
2 11/16"	HMY.2-11/16"
2 3/4"	HMY.2-3/4"
2 13/16"	HMY.2-13/16"
2 7/8"	HMY.2-7/8"
2 15/16"	HMY.2-15/16"
3"	HMY.3"



DoC 3" WeiNit

Ø 11/16" - 2 1/8"

DIA Ø	Code
11/16"	HMYU.11/16"
13/16"	HMYU.13/16"
15/16"	HMYU.15/16"
1 1/16"	HMYU.1-1/16"

DIA Ø	Code
1 1/8"	HMYU.1-1/8"
1 3/16"	HMYU.1-3/16"
1 1/4"	HMYU.1-1/4"
1 5/16"	HMYU.1-5/16"

DIA Ø	Code
1 3/8"	HMYU.1-3/8"
1 7/16"	HMYU.1-7/16"
1 1/2"	HMYU.1-1/2"
1 9/16"	HMYU.1-9/16"

DIA Ø	Code
1 5/8"	HMYU.1-5/8"
1 13/16"	HMYU.1-13/16"
1 7/8"	HMYU.1-7/8"
2 1/8"	HMYU.2-1/8"

DoC 75 mm Weldon

Ø 39 - 40 mm

DIA Ø	Code
39	HMY.390

DIA Ø	Code
40	HMY.400

TCT

DoC 4" Weldon Ø 7/16" - 8"

Weldon shank



WelNit shank



Shank sizes

DIA Ø 12 - 60 mm:
19.05 mm (3/4")

DIA Ø 61 - 200 mm:
31.75 mm (1 1/4")



DoC
Depth of Cut measured inside cutter

DIA Ø	Code
7/16"	HMX.7/16"
1/2"	HMX.1/2"
9/16"	HMX.9/16"
5/8"	HMX.5/8"
11/16"	HMX.11/16"
3/4"	HMX.3/4"
13/16"	HMX.13/16"
7/8"	HMX.7/8"
15/16"	HMX.15/16"
1"	HMX.1"
1 1/16"	HMX.1-1/16"
1 1/8"	HMX.1-1/8"
1 3/16"	HMX.1-3/16"
1 1/4"	HMX.1-1/4"
1 5/16"	HMX.1-5/16"
1 3/8"	HMX.1-3/8"
1 7/16"	HMX.1-7/16"
1 1/2"	HMX.1-1/2"
1 9/16"	HMX.1-9/16"
1 5/8"	HMX.1-5/8"
1 11/16"	HMX.1-11/16"
1 3/4"	HMX.1-3/4"
1 13/16"	HMX.1-13/16"

DIA Ø	Code
1 7/8"	HMX.1-7/8"
1 15/16"	HMX.1-15/16"
2"	HMX.2"
2 1/16"	HMX.2-1/16"
2 1/8"	HMX.2-1/8"
2 3/16"	HMX.2-3/16"
2 1/4"	HMX.2-1/4"
2 5/16"	HMX.2-5/16"
2 3/8"	HMX.2-3/8"
2 7/16"	HMX.2-7/16"
2 1/2"	HMX.2-1/2"
2 9/16"	HMX.2-9/16"
2 5/8"	HMX.2-5/8"
2 11/16"	HMX.2-11/16"
2 3/4"	HMX.2-3/4"
2 13/16"	HMX.2-13/16"
2 7/8"	HMX.2-7/8"
2 15/16"	HMX.2-15/16"
3"	HMX.3"
3 1/16"	HMX.3-1/16"
3 1/8"	HMX.3-1/8"
3 3/16"	HMX.3-3/16"
3 1/4"	HMX.3-1/4"

DIA Ø	Code
3 5/16"	HMX.3-5/16"
3 3/8"	HMX.3-3/8"
3 7/16"	HMX.3-7/16"
3 1/2"	HMX.3-1/2"
3 9/16"	HMX.3-9/16"
3 5/8"	HMX.3-5/8"
3 11/16"	HMX.3-11/16"
3 3/4"	HMX.3-3/4"
3 13/16"	HMX.3-13/16"
3 7/8"	HMX.3-7/8"
3 15/16"	HMX.3-15/16"
4"	HMX.4"
4 1/16"	HMX.4-1/16"
4 1/8"	HMX.4-1/8"
4 3/16"	HMX.4-3/16"
4 1/4"	HMX.4-1/4"
4 5/16"	HMX.4-5/16"
4 3/8"	HMX.4-3/8"
4 7/16"	HMX.4-7/16"
4 1/2"	HMX.4-1/2"
4 9/16"	HMX.4-9/16"
4 5/8"	HMX.4-5/8"
4 11/16"	HMX.4-11/16"

DIA Ø	Code
4 3/4"	HMX.4-3/4"
4 13/16"	HMX.4-13/16"
4 7/8"	HMX.4-7/8"
4 15/16"	HMX.4-15/16"
5"	HMX.5"
5 1/16"	HMX.5-1/16"
5 1/8"	HMX.5-1/8"
5 3/16"	HMX.5-3/16"
5 1/4"	HMX.5-1/4"
5 5/16"	HMX.5-5/16"
5 3/8"	HMX.5-3/8"
5 7/16"	HMX.5-7/16"
5 1/2"	HMX.5-1/2"
5 9/16"	HMX.5-9/16"
5 5/8"	HMX.5-5/8"
5 11/16"	HMX.5-11/16"
5 3/4"	HMX.5-3/4"
5 13/16"	HMX.5-13/16"
5 7/8"	HMX.5-7/8"
5 15/16"	HMX.5-15/16"
6"	HMX.6"
7"	HMX.7"
8"	HMX.8"

DoC 4" Weldon Ø 11/16" - 3 13/16"

DIA Ø	Code
11/16"	HMXU.11/16"
13/16"	HMXU.13/16"
15/16"	HMXU.15/16"

DIA Ø	Code
1 3/16"	HMXU.1-3/16"
2 5/16"	HMXU.2-5/16"
3 1/16"	HMXU.3-1/16"

DIA Ø	Code
3 9/16"	HMXU.3-9/16"
3 11/16"	HMXU.3-11/16"
3 13/16"	HMXU.3-13/16"

DoC 100 mm Weldon Ø 36 - 100 mm

DIA Ø	Code
36	HMX.360
59	HMX.590
60	HMX.600

DIA Ø	Code
87	HMX.870
89	HMX.890
90	HMX.900

DIA Ø	Code
94	HMX.940
95	HMX.950
97	HMX.970

DIA Ø	Code
100	HMX.1000

DoC 6" Weldon

Ø 7/16" - 8"

DIA Ø	Code
7/8"	HMW.7/8"
15/16"	HMW.15/16"
1"	HMW.1"
1 1/16"	HMW.1-1/16"
1 1/8"	HMW.1-1/8"

DIA Ø	Code
1 3/16"	HMW.1-3/16"
1 1/4"	HMW.1-1/4"
1 5/16"	HMW.1-5/16"
1 3/8"	HMW.1-3/8"
1 7/16"	HMW.1-7/16"

DIA Ø	Code
1 1/2"	HMW.1-1/2"
1 9/16"	HMW.1-9/16"
1 5/8"	HMW.1-5/8"
1 11/16"	HMW.1-11/16"
1 3/4"	HMW.1-3/4"

DIA Ø	Code
1 13/16"	HMW.1-13/16"
1 7/8"	HMW.1-7/8"
1 15/16"	HMW.1-15/16"
2"	HMW.2"

TCT

Weldon shank



DoC 6" WeINit

Ø 11/16" - 1 15/16"

DIA Ø	Code
11/16"	HMWU.11/16"
13/16"	HMWU.13/16"

DIA Ø	Code
15/16"	HMWU.15/16"
1 3/16"	HMWU.1-3/16"

DIA Ø	Code
1 11/16"	HMWU.1-11/16"
1 13/16"	HMWU.1-13/16"

DIA Ø	Code
1 15/16"	HMWU.1-15/16"

Shank sizes

DIA Ø 12 - 60 mm;
19.05 mm (3/4")

DIA Ø 61 - 200 mm;
31.75 mm (1 1/4")

DoC 8" Weldon

Ø 7/16" - 2"

DIA Ø	Code
7/8"	HMV.7/8"
15/16"	HMV.15/16"
1"	HMV.1"
1 1/16"	HMV.1-1/16"
1 1/8"	HMV.1-1/8"

DIA Ø	Code
1 3/16"	HMV.1-3/16"
1 1/4"	HMV.1-1/4"
1 5/16"	HMV.1-5/16"
1 3/8"	HMV.1-3/8"
1 7/16"	HMV.1-7/16"

DIA Ø	Code
1 1/2"	HMV.1-1/2"
1 9/16"	HMV.1-9/16"
1 5/8"	HMV.1-5/8"
1 11/16"	HMV.1-11/16"
1 3/4"	HMV.1-3/4"

DIA Ø	Code
1 13/16"	HMV.1-13/16"
1 7/8"	HMV.1-7/8"
1 15/16"	HMV.1-15/16"
2"	HMV.2"



DoC
Depth of Cut measured inside cutter

DoC 8" WeINit

Ø 13/16" - 3 13/16"

DIA Ø	Code
13/16"	HMVU.13/16"
15/16"	HMVU.15/16"
1 1/16"	HMVU.1-1/16"
1 3/16"	HMVU.1-3/16"
1 5/16"	HMVU.1-5/16"

DIA Ø	Code
1 11/16"	HMVU.1-11/16"
1 13/16"	HMVU.1-13/16"
1 15/16"	HMVU.1-15/16"
2 1/16"	HMVU.2-1/16"
2 3/16"	HMVU.2-3/16"

DIA Ø	Code
2 5/16"	HMVU.2-5/16"
2 7/16"	HMVU.2-7/16"
2 9/16"	HMVU.2-9/16"
2 11/16"	HMVU.2-11/16"
2 13/16"	HMVU.2-13/16"

DIA Ø	Code
3 1/16"	HMVU.3-1/16"
3 9/16"	HMVU.3-9/16"
3 11/16"	HMVU.3-11/16"
3 13/16"	HMVU.3-13/16"

Set TCT imperial

10 piece cutter sets



DoC 1"

- 10 piece annular cutter set
- Cutter sizes 2 x \varnothing 9/16", 2 x \varnothing 11/16", 2 x \varnothing 13/16", 2 x \varnothing 7/8", \varnothing 15/16", \varnothing 1"
- Pilot pins IBC.75 & IBC.85 included

TCT.KIT/10S-I1

DoC 1"

- 10 piece annular cutter set
- Cutter sizes 3 x \varnothing 9/16", 3 x \varnothing 13/16", 3 x \varnothing 7/8", \varnothing 15/16"
- Pilot pins IBC.75 & IBC.85 included

TCT.KIT/10S-I2



DoC 2"

- 10 piece annular cutter set
- Cutter sizes 2 x \varnothing 9/16", 2 x \varnothing 11/16", 2 x \varnothing 13/16", 2 x \varnothing 7/8", \varnothing 15/16", \varnothing 1"
- Pilot pins IBC.80 & IBC.90 included

TCT.KIT/10L-I1

DoC 2"

- 10 piece annular cutter set
- Cutter sizes 3 x \varnothing 9/16", 3 x \varnothing 13/16", 3 x \varnothing 7/8", \varnothing 15/16"
- Pilot pins IBC.80 & IBC.90 included

TCT.KIT/10L-I2

Hole Saw

Tungsten Carbide Tipped Hole Saw



Twist drills come in different materials and sizes, but above a certain diameter size it's no longer possible to drill with the twist drill. The amount of material to be cut would be too large and the drilling process would take extremely long. That's where the hole saws come in! With our multi-purpose TCT Hole saws you can drill holes from 7/16" up to 2" with portable power tools and stationary machines, without using extreme force or power. As the name suggests, the hole saw is hollow in the middle and only the cutting edges cut the material. This saves a lot of time and energy. The great thing about our hole saws is that they are very durable because they are Tungsten carbide tipped. Compared to bimetal hole saws they have a 10 times longer lifespan.

The hole saws are equipped with a pilot drill and ejector spring. The pilot drill allows simple centering and clean guidance in the material. With the ejector spring, the cut material is easily ejected from the hole saw. The safety stopper protects the workpiece (also a hex key is included for fixing the pilot drill).

- Material thickness for hand drills: max. 1/4"
- Recommended hole diameter for hand drills: max 1")
- Material thickness for portable magnetic drilling machines: max. 13/16"
- Parallel shank with 3 flats - Fits all common drill chucks

Diameter	Code
Ø 7/16"	THS.7/16"
Ø 1/2"	THS.1/2"
Ø 9/16"	THS.9/16"
Ø 5/8"	THS.5/8"
Ø 11/16"	THS.11/16"
Ø 3/4"	THS.3/4"
Ø 13/16"	THS.13/16"
Ø 7/8"	THS.7/8"
Ø 15/16"	THS.15/16"
Ø 1"	THS.1"
Ø 1 1/16"	THS.1-1/16"
Ø 1 1/8"	THS.1-1/8"
Ø 1 3/16"	THS.1-3/16"

Diameter	Code
Ø 1 1/4"	THS.1-1/4"
Ø 1 5/16"	THS.1-5/16"
Ø 1 3/8"	THS.1-3/8"
Ø 1 7/16"	THS.1-7/16"
Ø 1 1/2"	THS.1-1/2"
Ø 1 9/16"	THS.1-9/16"
Ø 1 5/8"	THS.1-5/8"
Ø 1 11/16"	THS.1-11/16"
Ø 1 3/4"	THS.1-3/4"
Ø 1 13/16"	THS.1-13/16"
Ø 1 7/8"	THS.1-7/8"
Ø 1 15/16"	THS.1-15/16"
Ø 2"	THS.2"



Specifications

Max. material thickness for drilling in:

- Steel with bench drill: approximately 13/16"
- Stainless steel with bench drill: approximately 3/8"
- Aluminium with bench drill: approximately 13/16"

TCT Hole Saw

- Shank: Ø 3/8"
- Max. depth of cut: 1 1/16"
- Wall thickness: 1/8"

Pilot pins

Pilot pins are essential for the use of annular cutters, as they provide the following practical uses:

- **Centration of cutter**
- **Control of oil flow**
- **Slug ejection**

As plain as a pilot pin may look, all of these uses require high-precision and extremely low tolerances – just to make sure the centre is exactly the centre, oil flow starts and stops when you need it to, and the slug does not get stuck inside the cutter.

We offer a wide range of pilot pins that match the lengths, diameters and characteristics of our various annular cutters with exactly the required precision to enhance your drilling job in the best way possible.

Overview

Code	Length pin	Diameter pin
IBC.70	3"	1/4"
IBC.75	3 9/16"	1/4"
IBC.80	4 1/16"	5/16"
IBC.85	3 9/16"	5/16"
IBC.90	4"	1/4"
IBC.100	4 13/16"	5/16"
IBC.110	6 1/4"	1/4"
IBC.120	4 3/4"	1/4"
IBC.130	6 1/2"	5/16"
IBC.140	5 15/16"	5/16"
IBC.150	29 15/16"	5/16"
IBC.160	7 15/16"	5/16"

Code	Length pin	Diameter pin
IBC.K25 ¹	5")	1/4"
IBC.K50 ¹	6 1/8")	1/4"
IBC.K75 ¹	7")	1/4"
IBC.K100 ¹	8")	1/4"
IBC.K110 ¹	6 1/4")	1/4"
IBC.2P-130 ²	5 1/8"	5/16"
IBC.2P-144 ²	5 11/16"	5/16"
IBC.157 ²	6 1/4"	5/16"
IBC.2P-168 ²	6 11/16"	5/16"
IBC.2P-205 ²	8 1/16"	5/16"
IBC.2P-256 ²	10 3/16"	5/16"

For our IBC.70 and IBC.90 pilot pins we also offer sets:

3 x IBC.70

3 x IBC.90

IBC.70-SET

IBC.90-SET

¹ Extended pilot pin

Specifically for use with long cutters and drilling in very thick workpieces. Makes it possible to continue drilling without mid-process replacement. Suitable for use with longer cutters as from 3".



² two-piece pilot pin

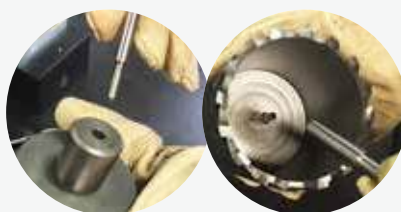

Place pilot pin through the shank, and attach extension through the bottom inside of the cutter.



Start drilling. Stop at approx. 50 mm depth.

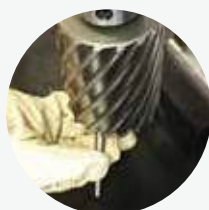

Remove the extension.

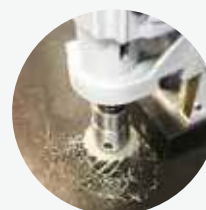

Commence drilling until slug ejection.



Pilot pins are essential for the use of annular cutters as they control the flow of oil, centre the cutter and make for a smooth slug ejection.

Pilot pin features

Precise positioning

- Whilst having a perfect fit the Euroboor pilot pin is your guidance to centre the cutter.



Material

Oil flow regulation

- In standstill position with the cutter above the workpiece, the pilot pin prevents the oil from flowing.
- When moving down the cutter with the pilot pin onto the workpiece to commence drilling, the pilot pin is pushed up into the arbor and permits the oil to flow into the cutter for direct cooling and lubricating.



Material

Slug ejection

- When the cutter is through the material, the pilot pin pushes the slug out of the workpiece by means of the strong spring inside the arbor.
- Consequently the oil flow is automatically cut off.



Material

Pilot pin recommendations



HSS imperial - 1"

HCS (DoC 1")	
Ø 7/16" - 2 5/16" IBC.70 (6.35 x 77 mm)	Ø 2 3/8" - 4" IBC.80 (8.00 x 103 mm)

HSS imperial - 2"

HCL (DoC 2")	
Ø 7/16" - 2 5/16" IBC.90 (6.35 x 102 mm)	Ø 2 3/8" - 4" IBC.100 (8.00 x 122 mm) IBC.2P-130 (8.00 x 130 mm)

HCLU (DoC 2")	
Ø 7/16" - 2 5/16" IBC.90 (6.35 x 102 mm)	

HSS Stack imperial - 2" & 3"

HCPL (DoC 2")	HCPY (DoC 3")
Ø 11/16" - 1 1/4" IBC.90 (6.35 x 102 mm)	Ø 11/16" - 1 1/4" IBC.K25 (6.35 x 127 mm)

HSS-Cobalt imperial - 1"

IBS (DoC 1")
Ø 7/16" - 2 5/16" IBC.70 (6.35 x 77 mm)

HSS-Cobalt imperial - 2"

IBL (DoC 2")
Ø 7/16" - 2 5/16" IBC.90 (6.35 x 102 mm)

HSS-Cobalt imperial - 3"

IBY (DoC 3")
Ø 7/16" - 2 5/16" IBC.K25 (6.35 x 127 mm)

TCT imperial - 1"

HMS (DoC 1")	
Ø 7/16" - 11/16" IBC.75 (6.35 x 90 mm)	3/4" - 4" IBC.80 (8.00 x 103 mm)

HMSU (DoC 1")	
Ø 7/16" - 11/16" IBC.75 (6.35 x 90 mm)	Ø 3/4" - 2 5/16" IBC.80 (8.00 x 103 mm)

TCT imperial - 2"

HML (DoC 2")	
Ø 7/16" - 11/16" IBC.90 (6.35 x 102 mm) 3/4" - 2 5/16" IBC.80 (8.00 x 103 mm)	Ø 2 3/8" - 8" IBC.100 (8.00 x 122 mm) IBC.2P-144 (8.00 x 145 mm)

HMLU (DoC 2")	
7/16" - 11/16" IBC.90 (6.35 x 102 mm) 3/4" - 2 15/16" IBC.80 (8.00 x 103 mm)	

TCT imperial - 3" & 4"

HMV (DoC 3")	HMX (DoC 4")
Ø 7/16" - 11/16" IBC.K25 (6.35 x 127 mm) Ø 3/4" - 3" IBC.140 (8.00 x 150 mm) IBC.157 (8.00 x 159 mm)	Ø 7/16" - 11/16" IBC.110 (6.35 x 159 mm) Ø 3/4" - 8" IBC.130 (8.00 x 165 mm) IBC.2P-168 (8.00 x 170 mm)

TCT imperial - 6" & 8"

HMW (DoC 6")	HMV (DoC 8")
Ø 7/8" - 8" IBC.160 (8.00 x 201 mm) IBC.2P-205 (8.00 x 206 mm)	Ø 7/8" - 8" IBC.150 (8.00 x 252 mm) IBC.2P-256 (8.00 x 258 mm)





ERM.100/3 Resharpener machine



Watch our machines in action on:
www.youtube.com/euroboorby

Technical data

Dimensions (l x w x h)	18 7/8" x 10 5/8" x 11 13/16"
Weight	61.7 lbs
Motor power	2.3 A
Noise emission	< 70 dBa
Grinding disk	Ø 4 15/16"
Wheel bore	Ø 1"
Shaft bore	3/4" Weldon
Speed (no load)	2,800 rpm
Voltage	110 - 120 V / 60 Hz

Benefits

- Resharpens HSS cutters from Ø 1/2" – 1 3/4" in cutting depths of 1" – 2 3/16"
- Easy angle adjustment; simple alignment to original geometry
- Laser guided cutter alignment ensures correct positioning of cutting edge to the wheel
- Motor positioning
- Including CBN* grinding wheel

* CBN = Cubic Borid Nitride



Cutter position at the cutter sharpening blade

Accessory ERM.100/3

Standard supply

CBN* Grinding wheel (Resharpener) For HSS

ERM3.0001

Index plate T4/T8 & T5/T10

ERM3.0009

Index plate T6 & T7

ERM3.0008

Index plate T9

ERM3.0010



Motor adjustment



Laser guidance

Weldon twist drills

HSS 19.05 mm (3/4") Weldon shank. 135° split point.
Available in 1" and 2" (DoC).

Machined from one solid blank (no weak spots caused by inferior material or welds).

COMING SOON

Individual Euroboor Twist Drills

Sets are available now



DoC 1"

DIA Ø 1/4" - 9/16"

INCH	Code
Ø 1/4"	SSPI.1/4"
Ø 5/16"	SSPI.5/16"
Ø 3/8"	SSPI.3/8"

INCH	Code
Ø 7/16"	SSPI.7/16"
Ø 1/2"	SSPI.1/2"
Ø 9/16"	SSPI.9/16"



DoC 2"

DIA Ø 1/4" - 9/16"

INCH	Code
Ø 1/4"	SPI.1/4"
Ø 5/16"	SPI.5/16"
Ø 3/8"	SPI.3/8"
Ø 7/16"	SPI.7/16"
Ø 1/2"	SPI.1/2"
Ø 29/64"	SPI.29/64"
Ø 31/64"	SPI.31/64"
Ø 9/16"	SPI.9/16"

DoC 50 mm

DIA Ø 8.5 - 11 mm

MM	Code
Ø 8.5MM	SPI.8.5
Ø 10MM	SPI.10
Ø 11MM	SPI.11



29 piece Drill Bit set

- Sizes Ø 1/16 - Ø 1/2 inch
- HSS - High Speed Steel - Black and Gold
- Fully ground, not roll-forged, for more stability
- DIN 338
- 118° split point
- 3-flats shank (11/64" and up)
- For non-ferrous metals, mild steel and cast iron
- Compatible with almost every drill chuck
- Drills also sold per 5 or 10 pieces

TDH.25

29 piece Drill Bit set

- Sizes Ø 1/16 - Ø 1/2 inch
- HSS-CO - Steel-cobalt alloy (5%)
- Fully ground, not roll-forged, for more stability
- DIN 338
- 135° split point
- 3-flats shank (11/64" and up)
- For hard materials and high alloy steel
- Compatible with almost every drill chuck
- Drills also sold per 5 or 10 pieces

TDC.25

Countersinks

- HSS 3/4" Weldon shank
- 3 cutting edges
- 90°

Weldon countersinks

Diameter	Code
Ø 3/8" - 1"	SCE.25
Ø 3/8" - 1 3/16"	SCE.30
Ø 3/8" - 1 9/16"	SCE.40
Ø 3/8" - 2"	SCE.50
Ø 15 - 50 mm	SCE.50/82



Step drills

- HSS TiN coated
- Spiral flute for efficient chip removal

Step drills

MM	Code
Ø 1/8" - 1/2"	ESD.INCH-A
Ø 1/4" - 3/4"	ESD.INCH-B
Ø 3/16" - 7/8"	ESD.INCH-C
Ø 3/16" - 1/2"	ESD.INCH-D
Ø 3/16" - 1/2"	ESD.INCH-E
Ø 7/8" - 1 1/8"	ESD.INCH-F
Ø 7/8" - 1 3/8"	ESD.INCH-G



After drilling aid



Magnetic stick for cleaning up metal shavings Ø 7/8" x 15 3/4"

Simply wave the magnetic stick over the metal shavings to pick them up, carry them over to your scrap barrel, pull the plunger and the shavings are neatly deposited. The Euroboor magic stick is strong enough to quickly clean up your biggest mess of metal shavings.

- Clean up sharp-edged metal chips, screws and other metal parts easily
- Items are safely ejected off of magic stick without hand contact
- Ideal for hard-to-reach spaces

MAGICSTICK



Tapping chucks

Morse Taper torque controlled tapping chucks

Specifically designed for use in combination with portable magnetic drilling machines.

Benefits

- + Quick and precise installation of taps
- + Increased operation accuracy
- + Drastically reduced risk of broken taps and destroyed threads

Features

- Slip clutch torque limiter
- Clear torque controller adjustment scale
- Full instruction manual including:
 - Installation and mounting guide
 - Torque setting guide
 - Tapping speed guide
 - m/min (ft/min) to rpm calculation
 - Cutting fluid recommendation
 - Maintenance guide
- Full "all parts" servicing possibility
- Complete delivery including:
 - 2 different rubber centration collets
 - All tools required for installation and adjustment



Torque controlled tapping chuck MT3

- Machine tap sizes M8 up to M20 (DIN 371 and DIN376)

ETC.2

- Machine tap sizes M14 up to M30 (DIN376)

ETC.3

Feature overview

	Morse Taper	Tap capacity	Slip clutch	Automatic reverse
ETC.2	MT3	M8 - M20	•	-
ETC.3	MT3	M14 - M30	•	-

Tap holders (Weldon)

All our tap holders are fitted with 3/4" Weldon shank

DIN 376

Tap holder	Shank	Code
M10	Ø 7 mm	TCM.10D376
M16	Ø 12 mm	TCM.16D376

ASA

Tap holder	Shank	Code
1/4"	Ø 6.5 mm	TCM.1/4"ASA
3/8"	Ø 9.68 mm	TCM.3/8"ASA
7/16"	Ø 8.2 mm	TCM.7/16"ASA
1/2"	Ø 9.29 mm	TCM.1/2"ASA
9/16"	Ø 10.9 mm	TCM.9/16"ASA
5/8"	Ø 12.17 mm	TCM.5/8"ASA
1"	Ø 20.2 mm	TCM.1"ASA



B60 Beveling machine

Watch our machines in action on:
www.youtube.com/euroboorby

Technical data	
Spindle speed	2,850 rpm
Max. bevel width	15/16" (45° angle)
Bevel angle	0° - 60°
Pipe diameter	Ø > 5 15/16"
Length	16 5/16"
Width	14 3/4"
Height	10 9/16"
Weight	49.2 lbs
Motor power	10.0 A
Voltage	110 - 120 V / 60 Hz

Benefits

- Powerful high-efficiency motor
- Smooth control with clear, precise and simple (protected) control buttons
- Suitable for pipe material Ø > 5 15/16"
- Simple replacement and indexation of the cutting plates
- Wide and soft handles

Features



Accessories B60



Milling head
 B60.0027



Carbide cutting plates
 (Sold per 10 pieces)
 LKS.15



Magnetic digital level box
 For measuring angles up to 90°
 MLB.90

B60S Beveling machine



Watch our machines in action on:
www.youtube.com/euroboorby

Technical data

Spindle speed	1,675 - 2,850 rpm
Max. bevel width	15/16" (45° angle)
Bevel angle	0° - 60°
Pipe diameter	Ø > 5 15/16"
Length	16 5/16"
Width	14 3/4"
Height	10 9/16"
Weight	54 lbs
Motor power	16.4 A
Voltage	110 - 120 V / 60 Hz



Benefits

- Powerful high-efficiency motor
- Smooth control with clear, precise and simple (protected) control buttons
- Suitable for pipe material Ø > 5 15/16"
- Simple replacement and indexation of the cutting plates
- Wide and soft handles
- Exceptional powerful motor (16.4 A)
- Extremely suitable for stainless steel (with the use of stainless steel guide plate)
- Overload protection

Features



Adjustable speed



Adjustment angle 0 - 60°



Bevel width 0 - 15/16"

Accessories B60S



Stainless steel plate

To use on stainless steel materials.

B60.1020S



Milling head

B60.0027



Carbide cutting plates

(Sold per 10 pieces)

LKS.15



Magnetic digital level box

For measuring angles up to 90°

MLB.90

B45S Beveling machine



Watch our machines in action on:
www.youtube.com/euroboorby

Technical data

Spindle speed	1,750 - 5,250 rpm
Max. bevel width	1/4" (45° angle)
Min. diameter for inside bevels	13/16"
Spindle thread	M12 x 1.75
Length	18"
Width	5 3/8"
Height	11 13/16"
Weight	9.7 lbs
Motor power	11.4 A
Voltage	110 - 120 V / 60 Hz

Benefits

- Ergonomic main handle, user-friendly controls, spindle speed adjustment range for various materials
- Quick and easy bevel width adjustment
- Clear bevel width indication
- Precision 45° milling head with 3 cutting edges (incl. cutting plates)
- Soft-grip front handle suitable for left- and right-handed users
- Electronic speed stabilization
- Anti-kickback and -breakthrough torque control (slow start)
- Quick and easy carbon brush replacement

Features



Adjustable speed



Overheat protection



Bevel width 0 - 1/4"



Accessories B45S



Carbide cutting plates
 Angle 30° & 45° (Sold per 10 pieces)
LKS.20



Carbide cutting plates
 R2.5 (Sold per 10 pieces)
LKS.20-R



Milling head
 Angle 30°
B45S.1011A



Angle 45°
B45S.1011



R2.5
B45S.1011B



Magnetic digital level box
 For measuring angles up to 90°
MLB.90

BM45AIR Mini Air Beveling machine



Watch our machines in action on:
www.youtube.com/euroboorby

Technical data

Spindle speed	28,000 rpm
Max. bevel width	1/16" (45°)
Length	5 29/32"
Height	1 25/32"
Weight	0.71 lbs
Air inlet	1/4"
Air hose	3/8"
Connector type	Euro type 1/4"
Avg. air consumption	0.15 m ³ /min (5 SCFM)
Working pressure	90 - 115 psi



Benefits

- Compact and great ergonomic design
- Lightweight machine
- Including 2x 45° and 2x R1.5 cutting plates
- Safety lever trigger to prevent accidental starts
- Bevel depth indicator for precise adjustment of the bevel size
- 6-speed air speed regulator

Features



Working pressure
90 - 115 PSI



Bevel width
1/16"
(45°) max.

Accessories BM45AIR



Cutting plate for steel. Angle 45°. (Sold per 10 pieces)

BM45AIR.45ST



Cutting plate radius 1.5 for steel. (Sold per 10 pieces)

BM45AIR.R1.5



Cutting plate for stainless steel. Angle 45°. (Sold per 10 pieces)

BM45AIR.45SS



Cutting plate for aluminum. Angle 45°. (Sold per 10 pieces)

BM45AIR.45ALU



Screw for BM45AIR cutting plate. Sold per piece.

BM45AIR.0009



Magnetic digital level box
For measuring angles up to 90°

MLB.90

ADG.2(A/S/E) Air die grinders

Technical data			
	ADG.2A	ADG.2S	ADG.2E
Weight	1.16 lbs	1.47 lbs	2.89 lbs
Free speed	20,000 rpm		22,000 rpm
Collet	1/4"		
Air inlet (PT)	1/4"		
Air hose (ID)	3/8"		
Avg. air consumption	4 SCFM (0,113 m ³ /min)	5 SCFM (0,142 m ³ /min)	
Working pressure	90 psi (6.3 bar)		
Length	7 5/8"		13 5/16"
Height	2 3/4"		

Benefits

- Excellent for grinding, polishing, deburring and smoothing sharp edges
- Four-speed rear regulator
- 360 degrees adjustable exhaust deflector
- Safety lever trigger



ADG.2E



ADG.2A



ADG.2S

Features



Adjustable
speed



Working
pressure
90 psi
(6.3 bar)

Available as

- Luxury case
- Standard 1/4" and 1/8" collet

ADG.2A-CASE / ADG.2S-CASE / ADG.2E-CASE





**COMING
SOON**

Euroboor Rotary Burrs:

Single cut
Double cut
Diamond cut
Alu cut

EDC.355 Dry cut-off saw

Watch our machines in action on:
www.youtube.com/euroborby

Technical data	
Dimensions (l x w x h)	24 7/16" x 13 3/4" x 24 13/16"
Weight	41 lbs
Motor power	11 A
Cutting speed (no load)	1,450 rpm
Cutting angle	adjustable, 0° - 45°
Bore size	Ø 1"
Cutting capacity at 0°	● 4 3/4"
	■ 4 1/8" x 4 1/8"
	■ 3 9/16" x 5 11/16"
Cutting capacity at 45°	● 3 9/16"
	■ 3 1/8" x 3 1/8"
	■ 3 9/16" x 3 1/8"
Max. Ø saw blade	14"
Voltage	110 - 120 V / 60 Hz



Benefits

- Adjustable sawing angle from 0° to 45°
- Molded aluminum base with adjustable angle indication.
- 3 attachment points to fix the machine to your workbench.
- Ergonomic handle and locking pin to easily carry the machine
- Safety button for protection against accidental start-up.
- Transparent protective shield for safely discharging of the chips
- Robust clamp for very precise clamping of materials
- Dust collection tray for a cleaner workspace
- Built-in soft-start functionality



Mounting holes



Dust collection tray



Easy blade replacement



Adjustable vice 0° - 45°

Features



Cutting capacity
4 3/4"



Adjustment angle
0 - 45°

Accessory EDC.355



Saw blade 14", 66 teeth, bore 1"

130.355/66



Saw blade 14", 66 teeth, bore 1", for mild steel

130.355/66/M



Saw blade 14", 80 teeth, bore 1"

130.355/80

EHC.230/3 Dry cut-off saw



Watch our machines in action on:
www.youtube.com/euroboorby

Technical data

Dimensions (l x w x h)	16 9/16" x 8 1/4" x 14 9/16"
Weight	21.4 lbs
Motor power	16.4 A
Cutting speed (no load)	2300 rpm
Cutting angle, adjustable	0 - 45°
Bore size	Ø 1"
Max. Saw depth 0°	3 1/4"
Max. Saw depth 45°	2 1/4"
Max. Ø Saw blade	9 1/16"
Max. Continuous use	45 minutes
Continuous capacity	1/4"
Cut-off capacity	1/8" - 3/8", built in laser indication
Voltage	110 - 120 V / 60 Hz



Benefits

- Wide and stable guide plate
- Integrated cutting length indication
- Swivel functionality, up to 45°
- Built-in laser indicator
- Retracting full blade protection
- Durable safety covers
- Quick-release chip collector
- Easily accessible carbon brushes



Adjustable cutting angle, up to 45°



Stable guide plate

Accessory EHC.230/4



saw blade 9", 48 teeth, bore 1"

Art. nr.: 230.0003

Features



Cutting capacity
83 mm



Adjustment angle 0 - 45°

Lifting magnets

Euroboor lifting magnets are engineered with top priority on safety and practical use. This attention to detail during the manufacturing process makes it possible to combine high-uniform magnetic strength with easy and smooth handle operation. The compact design and limited weight make the magnets easy to handle, optimize workspace and fully exploit crane capacity.

Safety factor 3.5

Euroboor lifting tools are designed to withstand at least 3.5 times the recommended workload and each lifting magnet is individually tested and delivered with a specific certificate as proof of safety. Our lifting tools provide reliable and consistent performance, also under extreme conditions.

Benefits:

- **Safety factor 3.5; Lift at least 3.5 times the suggested weight load**
- **Suitable for flat and tubular objects**
- **Suitable for rough or finished surfaces**
- **High lifting capacity**
- **Suitable for temperatures up to 176 °F**
- **Maintenance free**
- **Certified safety**
- **Reliable and consistent performance, also under extreme conditions**
- **Easy handling and operation**

Model	ELM.125	ELM.250	ELM.500	ELM.1000	ELM.2000
Dimensions (l x w x h)	5 13/32" x 2 7/16" x 4 3/8"	7 13/16" x 3 9/16" x 6 7/16"	10 3/8" x 4 1/2" x 7 1/4"	11 15/16" x 5 15/16" x 9"	16 5/16" x 7 1/2" x 11 11/16"
Ø of eye	53/64"	1 1/2"	1 21/32"	1 31/32"	2 13/64"
Weight	8.8 lbs	21.6 lbs	42.4 lbs	84 lbs	209.6 lbs
Workload Limit flat material	250 lbs	500 lbs	1,000 lbs	2,000 lbs	4,000 lbs
Workload limit round material	120 lbs	250 lbs	500 lbs	1,000 lbs	2,000 lbs
Plate minimal thickness	5/32"	5/32"	1/4"	3/8"	19/32"
Ø min/max	1 37/64" - 3 5/32"	1 31/32" - 3 15/16"	3 15/16" - 9 27/32"	5 29/32" - 14 61/64"	7 3/32" - 17 23/32"
Max working temp.	176 °F	176 °F	176 °F	176 °F	176 °F





Lifting magnet 250 lbs
ELM.125



Lifting magnet 500 lbs
ELM.250



Lifting magnet 1000 lbs
ELM.500



Lifting magnet 2,000 lbs
ELM.1000



Lifting magnet 4,000 lbs
ELM.2000



World wide

Euroboor is currently serving an increasing amount of more than 70 countries, covering all continents. With multiple offices throughout the world and many committed distributors. We are proud to be a close-knit team of international employees with shared values and ambitions, ready to make your working day an easier day.



Stock

Euroboor is a privately owned company with in-house production and continuous supply to each of our offices. Whatever your needs are, we strive to serve you with the best possible solutions on the shortest term possible.



Fast delivery

With a fine network of stock keeping offices, distributors and wholesalers, Euroboor will make sure your orders are being supplied with the speed and care they deserve.



Tech support

Our qualified staff of specialists can help you with all your technical requests. Whether it comes down to our offerings, servicing your tool or advise on the most difficult drilling tasks, there is hardly anything we have not dealt with before.



Premium parts

Our complete product range is built on proper quality standards. Throughout the lifecycle of your tools, we will make sure these standards are being kept with supplying you only original manufacturing spare parts.

Metal workers choice



Our company logo represents the slug created with the use of our annular cutters – the solid Euroboor core of your metal working job.

Don't forget! Register your machine

Make sure to fill in our register form on our website as soon as you can and double the warranty period on your machine(s). This applies to all Euroboor power tools.

Registration benefits:

- ✓ Warranty up to 24 months;
- ✓ Registered repair history;
- ✓ Fast and professional service;
- ✓ Up-to-date product information;
- ✓ Get information about special offers.

www.euroboor.com/usa/support/register



Euroboor newsletter Stay connected with us!

Subscribe to our newsletter and stay informed about our newest innovations, latest news and amazing deals.

Go to www.euroboor.com, fill in your email address and confirm your registration by clicking on the link in your personal confirmation email.





Abridged version of the general terms and conditions

of (i) EUROBOOR B.V., in Zoetermeer The Netherlands, (ii) Euroboor USA Inc., Hayden, USA.,
(iii) Euroboor LC, St. Petersburg, Russia, (iv) Euroboor LC, Chelyabinsk, Russia,
(v) MEEBS FZE, Sharjah, UAE, (vi) Euroboor Metal Constructions Instruments Co., Zhangjiagang, China

1. General

All our offers, quotations, agreements and their implementation are subject to the general terms and conditions, as amended from time to time, and as deposited at the chamber of commerce and industry in the Hague under registration 27125112. The applicability of all other (general) terms and conditions, in particular those of the customer and/or contractor ("customer") is excluded. This abridged version merely serves as an introduction to the complete set of our general terms and conditions referred to in the foregoing. In case of contradiction between the terms of this abridged version and the general terms and conditions, the latter shall prevail.

2. Quotations

Our quotations, in whatever form, are not binding upon us and merely constitute an invitation to the customer to place an order. All information and/or data provided with quotations remain our intellectual property. We are not liable for incorrect information provided along with our quotations.

3. Agreements

Agreements, including further commitments and/or modifications, are only binding following our explicit written confirmation or acceptance.

4. Prices

Our prices are based on delivery exw (prevailing incoterms) and are exclusive of value added tax, shipping, etc. We reserve the right to change prices.

5. Deliveries and leadtimes

Delivery times are stated as approximate. Excess of delivery times does not give rise to any claims for damages by the customer in any event. Cancellation is only permitted after

repeated excess of delivery times, and only following written notice of default by the customer.

6. Liability

Our liability for any and all claims for damages arising out of or in connection with the sale and delivery of the goods and the use thereof shall under no circumstances exceed the sum of customer's payments for the goods that are the subject of any such claim.

7. Complaints

Complaints about the goods supplied must be made in writing and must reach us no later than seven (7) days from the date of delivery, or seven (7) days from the date on which the basis for a complaint was or ought to have been apparent.

8. Payment and retention of title

Payment shall be made into our bank account no later than 30 days after date of invoice. Interest shall be due in case of late payment. The ownership of the goods shall not pass to customer, and full legal and beneficial ownership of the goods shall remain with us, unless and until we have received payment for the goods in full. We are entitled to demand payment guarantees prior to delivery.

9. Disputes and applicable law

The laws of the Netherlands shall apply and suits, actions or proceedings that may be instituted by any party shall be at the competence of the courts in the district of Rotterdam, the Netherlands.

Euroboor worldwide



The Netherlands



Brasil



Russia



China



United States of America



United Arab Emirates



www.euroboor.com



The Netherlands office

Kryptonstraat 110
2718 TD Zoetermeer
t +31(0)79 361 49 90
e info.nl@euroboor.com



Brasil office

Rua Harpia 438 Novo Horizonte, Serra, 29.163-308
Espírito Santo, Brasil
t +55 27 98827 1043
e contato.br@euroboor.com

Russia offices

st. Latyshskih Strelkov 29/4
195213 St.Petersburg
t 8 800 201 41 78
8 812 679 00 28
e info.russia@euroboor.com

st. Geroev Tankograda 46 P
454084 Chelyabinsk
t 8 800 201 41 78 (add 222)
8 812 679 00 28 (add 222, 104)
e ural@euroboor.com

UAE office

SAIF Zone A2-084
P.O. Box No: 120085, Sharjah
t +971 655 784 54
e info.uae@euroboor.com

USA office

160 White Oak Road
Hayden, AL 35079
t +1 844 266 85 27
e info.usa@euroboor.com

China office

2nd Floor, HongJi Building. No9#, LiuShi Road,
LiXiang Village, Tangshi
Yangshe Town, ZhangJiagang City,
Jiangsu China 215600
t +8651258549182
e info@euroboorchina.com

www.euroboor.com



 **EUROBOOR**

FOR PROFESSIONALS BY PROFESSIONALS



CAT-JULY-2023